

# KOSHIN

## GEAR PUMP

### OPERATION MANUAL

#### 《GL MODEL》

- Thank you for purchasing this product.
- This manual is prepared for your safety when operating pump.  
Please read carefully and comprehend fully before use.  
(Wrong usage could cause injury or death)
- Please keep this manual handy for future reference.

**Please read this manual before operation.**

## CAUTION

### 1. Application

- Refrain from using such liquid as solvent, acid, or alkali because the pump is for oil.

### 2. Pump Setting Method

#### a) How to attach the pump

- Shaft center adjustment

Adjust the shaft center of the pump to the shaft center of the motor exactly while fitting a scale or the like so as to avoid any step difference. (See Fig. 1.)

For fine adjustment, please use the attached adjust washer. (See Fig. 2)

Fig. 1

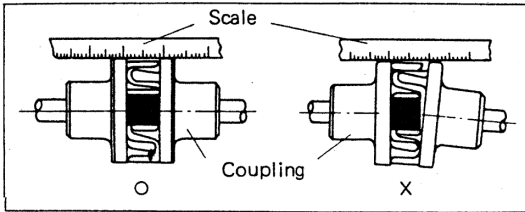
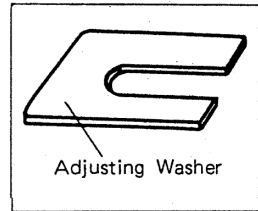

Fig. 2



- Fixing the coupling

Fix the coupling firmly onto the pump shaft by inserting a hexagon screw into the coupling at the pump side, then fastening the screw tightly over the woodruff key with a hexagon wrench so as the coupling may not move along revolution of the pump. (See Fig. 3)

Fig. 3

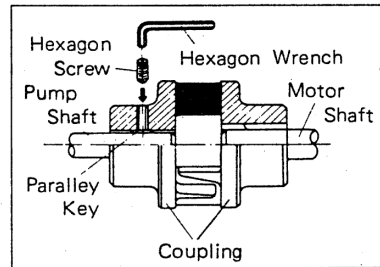

#### b) Revolutional direction of pump

The pump should turn to the right, i.e. clockwise direction looking from the motor side. Check the revolutional direction with the arrow mark indicated on the front cover. In forward direction, the right side looking from the motor side is the delivery outlet and the left side is the suction inlet.

Refrain from turning the pump in counterclockwise direction as the relief valve incorporated in the pump does not operate, which is very dangerous.

#### c) Suction piping

For the suction piping, pay close attention to prevent any cavitation in the pump due to the suction resistance. When a high viscosity liquid such as engine oil or B heavy oil is used under a cold climate condition, cavitation tends to be resulted and noise, abnormal wear of gears and other parts, and damage to mechanical seal are resulted.

## HOW TO USE

1. Turn on the switch after making sure the revolutional direction of the pump.
2. Before starting continuous operation, check the operational condition by turning on and off the switch for trial.
3. Before turning off the switch to stop the pump, open the delivery side valve fully.

## CAUTION

1. The figures at the end of each type designation (GL XX-5, GL XX-10) indicate the pressure when the relief valve starts to open, 0.5MPa (5kgf/cm<sup>2</sup>), and 1MPa (10kgf/cm<sup>2</sup>), respectively, and these are selected with due consideration to the piping resistance and throttle pressure etc.
2. Applicable viscosity differs depending on each type, power output, rate of revolution, piping and suction condition. Ordinarily, an oil within the viscosity range from 5 mm<sup>2</sup>/s(cst) to 500 mm<sup>2</sup>/s(cst) should be used.
3. For operation, keep the liquid temperature below 60°C.
4. Idling is prohibitive.  
Absolutely refrain from idling when kerosine, diesel, A heavy oil and other low and other low viscosity oil is used because the bearings in the pump are lubricated by the liquid transferred.
5. Refrain from closing the delivery valve while the pump is in operation.  
A by-pass valve is incorporated in the pump but this is only for safety. Never close the delivery valve while the pump is in operation as such is extremely dangerous because the oil temperature in the pump is increased.
6. When the pump is stopped for a long time, prevent rusting in the pump by taking out the transfer liquid in the pump and supplying grease, machine oil and others.

## MAKING CABITATION

1. Lower the setting position of the pump as far as possible so as to increase the suction side liquid pressure. (Fig. 4.)
2. Make the suction piping as short as possible.
3. Use a little larger pipes as the suction pipe. (Fig. 5)
4. When any suction hose is used, employ larger size by one step than the one of nominal size in general, i.e. the hose of the same I.D. as that for gas pipe. (Fig. 5)
5. Air allowed into the suction pipe generates unusual noise and causes abrasion of the pump. Seal the joints of suction pipe completely.

Fig 4

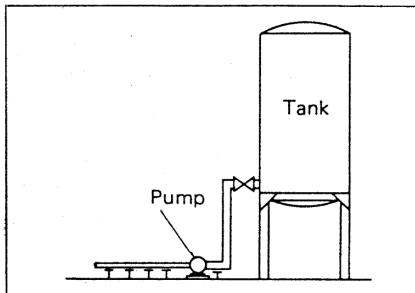
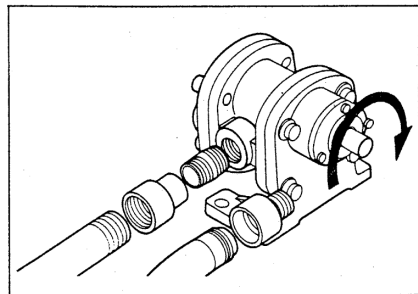
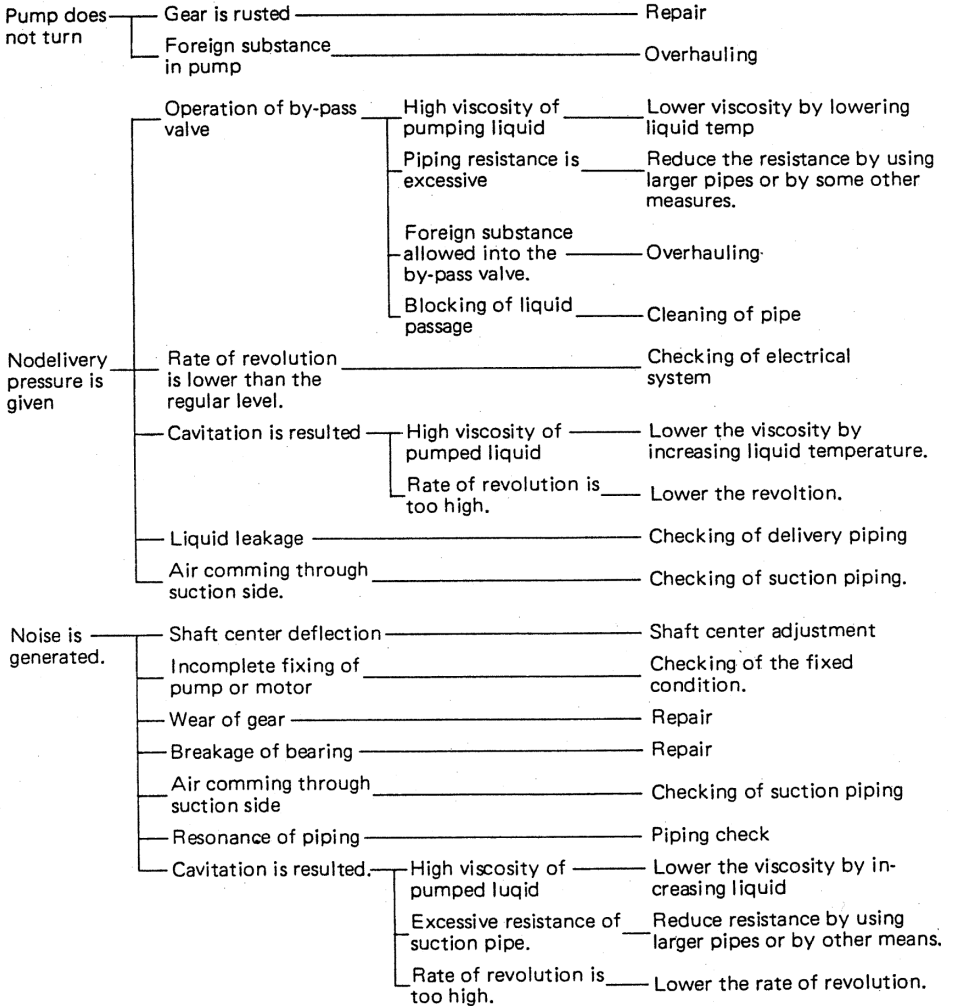

Fig 5



# TROUBLE & REMEDY



# SPECIFICATION

Pump Model	Curve No	Motor Power	Connection Dia	Max Pressure	Delivery volume		Cabling Material	Pump Shaft Dia		
					60Hz (1800rpm)	50Hz (1500rpm)				
GL-13-5	①	0.4kw4p 200V 3phase	G $\frac{1}{2}$ "	0.5MPa	20 ℓ /min	17 ℓ /min	ZDC	φ18		
GL-13-10	②	0.75kw4p 200V 3phase		1MPa	5.3U.S.G/min	4.5U.S.G/min				
GL-20-5	③	0.75kw4p 200V 3phase	G $\frac{1}{2}$ "	0.5MPa	35 ℓ /min	29 ℓ /min				
GL-20-10	④	1.5kw4p 200V 3phase		1MPa	9.2U.S.G/min	7.7U.S.G/min				
GL-25-5	⑤	1.5kw4p 200V 3phase	G1"	0.5MPa	55 ℓ /min	46 ℓ /min				
GL-25-10	⑥	2.2kw4p 200V 3phase		1MPa	14.5U.S.G/min	12.1U.S.G/min				
GL-32-5	⑦	3.7kw4p 200V 3phase	G1 $\frac{1}{2}$ "	0.5MPa	80 ℓ /min	66 ℓ /min				
GL-32-10	⑧	3.7kw4p 200V 3phase		1MPa	21.1U.S.G/min	17.4U.S.G/min				
GL-40-5	⑨	2.2kw6p 200V 3phase	G1 $\frac{1}{2}$ "	0.5MPa	123 ℓ /min	100 ℓ /min			FC	φ22
GL-40-10	⑩	5.5kw6p 200V 3phase		1MPa	32.5U.S.G/min (1200rpm)	26.4U.S.G/min (1000rpm)				
GL-50-5	⑪	3.7kw6p 200V 3phase	G2"	0.5MPa	200 ℓ /min	165 ℓ /min				
GL-50-10	⑫	7.5kw6p 200V 3phase		1MPa	52.8U.S.G/min (1200rpm)	43.6U.S.G/min (1000rpm)				

· The specification is subject to change without notice for improvement.

# PERFORMANCE CURVE

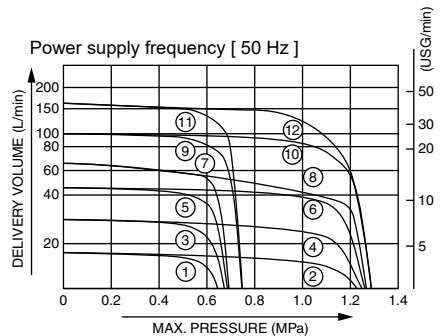
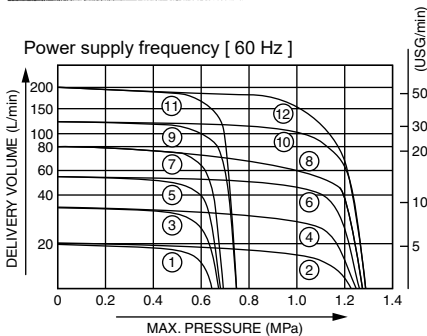

## DIMENSION

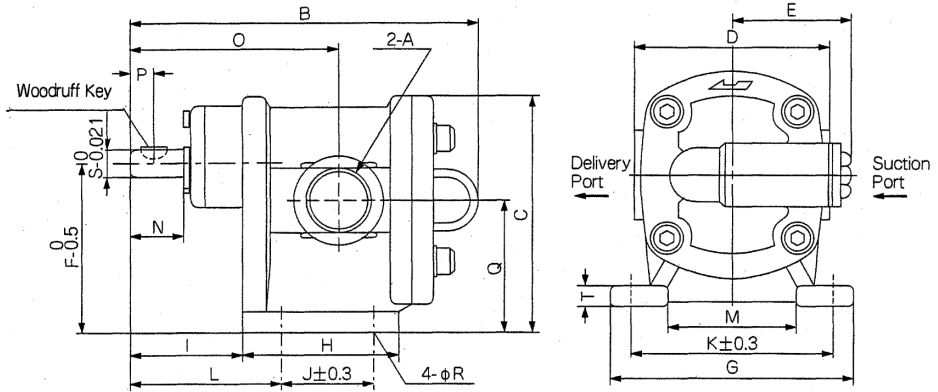

TYPE	A	B	C	D	E	F	G	H	I	J	K	L	M	N	O	P	Q	R	S	T	U
GL-13-□	G <sup>3</sup> / <sub>8</sub> "	189	131	108	64.5	95	138	73	71	40	116	87	58	30	113	15	75	11	18	12	4×19
GL-20-□	G <sup>3</sup> / <sub>8</sub> "	196	131	108	64.5	95	138	73	71	40	116	87	58	30	117	15	75	11	18	12	4×19
GL-25-□	G1"	208	131	108	64.5	95	138	73	71	40	116	87	58	30	122	15	75	11	18	12	3×19
GL-32-□	G1 <sup>1</sup> / <sub>4</sub> "	222	131	108	64.5	95	138	73	71	40	116	87	58	30	130	15	75	11	18	12	4×19
GL-40-□	G1 <sup>1</sup> / <sub>2</sub> "	265	189	148	89.5	136	184	112	86	70	156	111	100	40	158	19	106	11	22	16	5×22
GL-50-□	G2"	290	189	148	89.5	136	184	112	86	70	156	111	100	40	170	19	106	11	22	16	5×22

## COUPLING DIMENSION

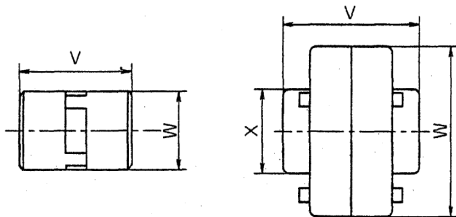

GL-13-□, GL-20-□,  
GL-25-5

GL-25-10, GL-32-□,  
GL-40-□, GL-50-□

	V	W	X	Parts No.
GL-13-□	69	55	/	0078022
GL-20-□				
GL-25-5				
GL-25-10	93	125	50	0078023
GL-32-□	93	125	50	0078024
GL-40-5	103	140	63	0078025
GL-40-10	103	140	63	0078025
GL-50-5	115	160	80	0078026
GL-50-10	115	160	80	0078026



# **KOSHIN LTD.**

[www.koshinpump.com](http://www.koshinpump.com)

TEL.: +81-75-953-2499 FAX.: +81-75-954-6119

E-mail: [info@koshin-ltd.co.jp](mailto:info@koshin-ltd.co.jp)

12 Kami-Hachinotsubo Kotari, Nagaokakyo City,  
Kyoto 617-8511 JAPAN