

## DIMENSION

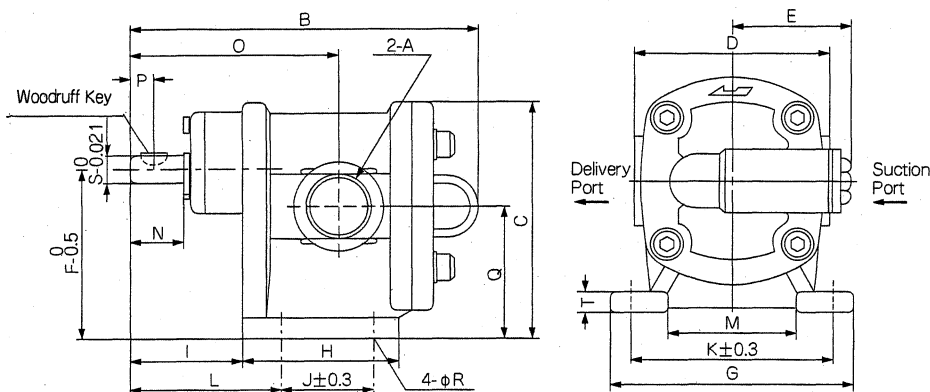

TYPE	A	B	C	D	E	F	G	H	I	J	K	L	M	N	O	P	Q	R	S	T	U
GL-13-□	PS½	189	131	108	64.5	95	138	73	71	40	116	87	58	30	113	15	75	11	18	12	4×19
GL-20-□	PS¾	196	131	108	64.5	95	138	73	71	40	116	87	58	30	117	15	75	11	18	12	4×19
GL-25-□	PS1	208	131	108	64.5	95	138	73	71	40	116	87	58	30	122	15	75	11	18	12	3×19
GL-32-□	PS1¼	222	131	108	64.5	95	138	73	71	40	116	87	58	30	130	15	75	11	18	12	4×19
GL-40-□	PS1½	265	189	148	89.5	136	184	112	86	70	156	111	100	40	158	19	106	11	22	16	5×22
GL-50-□	PS2	290	189	148	89.5	136	184	112	86	70	156	111	100	40	170	19	106	11	22	16	5×22



# GEAR PUMP

## High Performance Gear Pump

### OPERATION MANUAL

### 《GL MODEL》

- Thank you for purchasing KOSHIN GEAR PUMP.
- This manual is prepared for your safety when operating pump. Please read carefully and comprehend fully before use. (Wrong usage could cause injury or death.)
- Please keep this manual handy for future reference.

**Please read this manual before operation.**

## COUPLING DIMENSION

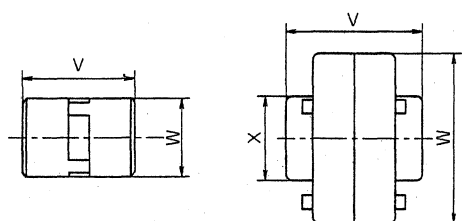

GL-13-□, GL-20-□,  
GL-25-5

GL-25-10, GL-32-□,  
GL-40-□, GL-50-□

	V	W	X	Parts No.
GL-13-□				0078022
GL-20-□	69	55		
GL-25-5				
GL-25-10	93	125	50	0078023
GL-32-□				0078024
GL-40-5	93	125	50	
GL-40-10	103	140	63	0078025
GL-50-5				0078026
GL-50-10	115	160	80	

**KOSHIN LTD.** [www.koshinpump.com](http://www.koshinpump.com)

12 Kami-Hachinotsubo Kotari, Nagaokakyo City, Kyoto 617-8511 JAPAN  
TEL.+81-75-954-6111 FAX.+81-75-954-6119

## CAUTION

### 1. Application

- Refrain from using such liquid as solvent, acid, or alkali because the pump is for oil.

### 2. Pump Setting Method

#### a) How to attach the pump

- Shaft center adjustment

Adjust the shaft center of the pump to the shaft center of the motor exactly while fitting a scale or the like so as to avoid any step difference. (See Fig. 1.) For fine adjustment, please use the attached adjust washer. (See Fig. 2)

Fig. 1

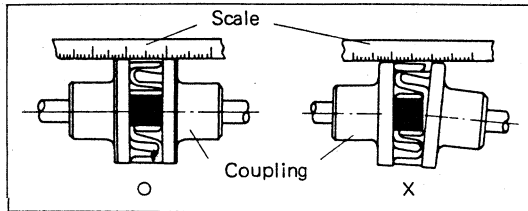
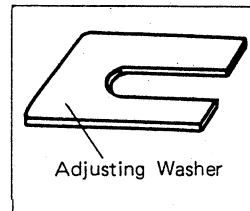
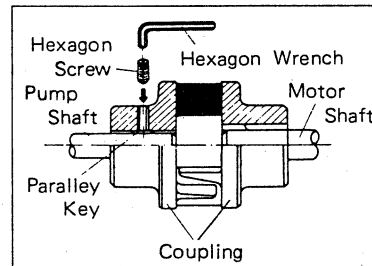

Fig. 2



- Fixing the coupling

Fix the coupling firmly onto the pump shaft by inserting a hexagon screw into the coupling at the pump side, then fastening the screw tightly over the woodruff key with a hexagon wrench so as the coupling may not move along revolution of the pump. (See Fig. 3)



#### b) Revolutions direction of pump

The pump should turn to the right, i.e. clockwise direction looking from the motor side. Check the revolutions direction with the arrow mark indicated on the front cover. In forward direction, the right side looking from the motor side is the delivery outlet and the left side is the suction inlet.

Refrain from turning the pump in counterclockwise direction as the relief valve incorporated in the pump does not operate, which is very dangerous.

#### c) Suction piping

For the suction piping, pay close attention to prevent any cavitation in the pump due to the suction resistance. When a high viscosity liquid such as engine oil or B heavy oil is used under a cold climate condition, cavitation tends to be resulted and noise, abnormal wear of gears and other parts, and damage to mechanical seal are resulted.

## HOW TO USE

1. Turn on the switch after making sure the revolutions direction of the pump.
2. Before starting continuous operation, check the operational condition by turning on and off the switch for trial.
3. Before turning off the switch to stop the pump, open the delivery side valve fully.

## PARTS LIST

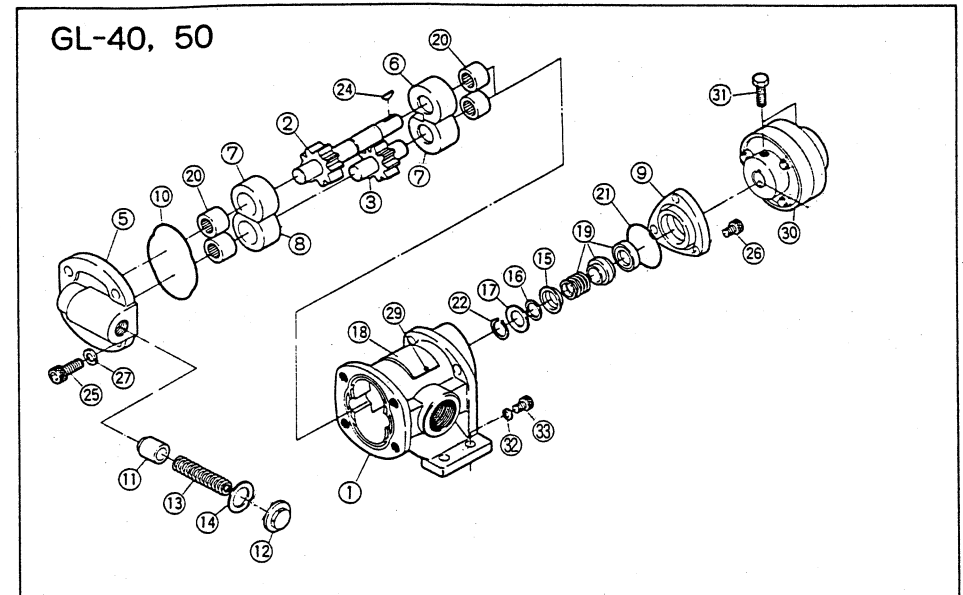

No.	PARTS No.	PARTS NAME	QTY	MATERIAL	No.	PARTS No.	PARTS NAME	QTY	MATERIAL
1	GL-40 0070170	Housing	1	FC	16	0090114	Stopper packing	1	NBR
	GL-50 0070171				17	0070138	Stopper plate	1	SPC
2	GL-40 0070158	Drive gear	1	SCM	18	—	Name plate	1	
	GL-50 0070159				19	0111153	Mechanical seal	1	HG9A-MNφ25
3	GL-40 0070164	2nd gear	1	SCM	20	927500028	Needle bearing	4	RLM253225
	GL-50 0070165				21	889955055	O-ring	1	G55 NBR
5	0070033	Bypass cover	1	FC	22	888327025	Shaft stop-ring	1	
6	0070080	Bush with flute	1	FC,BC	24	886909010	Woodruff key	1	S45C
7	0070124	Bush B	2	FC,BC	25	734532149	Hexagon socket bolt	4	M14×40SCM
8	0070043	Bush A	1	FC,BC	26	743119032	Hexagon bolt	3	M6×20SCM
9	0070137	Foot cap	1	FC	27	843822014	Spring washer	4	φ14
10	0070134	Particular O-ring	1	NBR	29	854505006	Parker rivet	2	SUS
11	0070110	Popet	1	S35C	30	See another list	JIS Coupling	1	
12	0070109	Bypass cap	1	FC-20	31	735719148	Hexagon bolt	1	M8×20
13	※1	Spring	1	SWP	31	735719152	Hexagon bolt	1	M8×30(GL-50-10)
14	0070048	Valve packing	1		32	0340142	Seal ring	2	NBR
15	0090115	Stopper	1	SUS	33	0340153	Bind screw	2	M6×8SUS

※1 Spring 0.5MPa (5kgf/cm<sup>2</sup>)TYPE : GL-40-5, GL-50-5

→ 0070078

1MPa (10kgf/cm<sup>2</sup>)TYPE : GL-40-10, GL-50-10

→ 0070079

## PARTS LIST

GL-13, 20, 25, 32

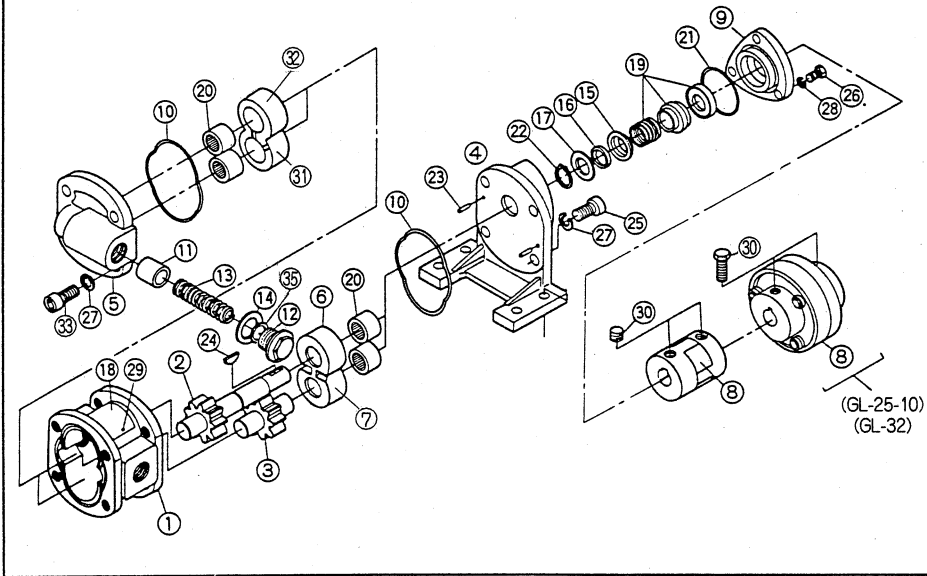

No.	PARTS No.	PARTS NAME	QTY	MATERIAL	No.	PARTS No.	PARTS NAME	QTY	MATERIAL
1	GL-13 0070004	Housing	1	FC	14	0070038	Valve packing	1	
	GL-20 0070003			ADC	15	0070133	Stopper	1	SUS
	GL-25 0070002			ADC	16	0070126	Stopper packing	1	NBR
	GL-32 0070001			FC	17	0070125	Stopper plate	1	SPC
2	GL-13 0070153	Drive gear	1	SCM	18	—	Name plate	1	
	GL-20 0070154				19	0070258	Mechanical seal	1	HG9ALN-3φ20
	GL-25 0070155				20	927500021	Needle bearing	4	RLM202820
	GL-32 0070156				21	890155045	O-ring	1	S45 NBR
3	GL-13 0070160	2nd gear	1	SCM	22	888327020	Shaft stop-ring	1	
	GL-20 0070161				23	848609077	Parallel pin	2	
	GL-25 0070162				24	887009007	Woodruff key	1	S45C
	GL-32 0070163				25	734532090	Hexagon socket bolt	4	M10×25SCM
4	0070283	Foot cover	1	ADC	26	734532035	Hexagon socket bolt	3	M5×16SCM
5	0070284	Bypass cover	1	ADC	27	843822010	Spring washer	8	φ10
6	0070317	Bush with flute	1	FC	28	843822005	Spring washer	3	φ5
7	0070318	Bush B	1	FC	29	854505006	Parker rivet	2	SUS
8	See another list	Coupling	1		30	713832026	Hexagon socket screw	1	M6×10SCM
9	0070141	Foot cap	1	ADC	30	735719148	Hexagon bolt	1	M8×20
10	0070131	Particular O-ring	1	NBR	31	0070319	Bush A	1	FC
11	0070106	Popet	1	S35C	32	0070320	Bush B heat-treated	1	FC
12	0070105	Bypass cap	1	ZDC	33	734532088	Hexagon socket bolt	4	M10×20SCM
13	※1	Spring	1	SWP	35	0070095	Bypass adjusting plate	1	SPCC

※1 Spring 0.5MPa (5kgf/cm<sup>2</sup>) TYPE : GL-13-5, GL-20-5, GL-25-5, GL-32-5  
→ 0070077

1MPa (10kgf/cm<sup>2</sup>) TYPE : GL-13-10, GL-20-10, GL-25-10, GL-32-10  
→ 0070026

## CAUTION

- The figures at the end of each type designation (GL XX-5, GL XX-10) indicate the pressure when the relief valve starts to open, 0.5MPa (5kgf/cm<sup>2</sup>), and 1MPa (10kgf/cm<sup>2</sup>), respectively, and these are selected with due consideration to the piping resistance and throttle pressure etc.
- Applicable viscosity differs depending on each type, power output, rate of revolution, piping and suction condition. Ordinarily, an oil within the viscosity range from 5 mm<sup>2</sup>/s(cst) to 500 mm<sup>2</sup>/s(cst) should be used.
- For operation, keep the liquid temperature below 60°C.
- Idling is prohibitive.  
Absolutely refrain from idling when kerosine, diesel, A heavy oil and other low and other low viscosity oil is used because the bearings in the pump are lubricated by the liquid transferred.
- Refrain from closing the delivery valve while the pump is in operation.  
A by-pass valve is incorporated in the pump but this is only for safety. Never close the delivery valve while the pump is in operation as such is extremely dangerous because the oil temperature in the pump is increased.
- When the pump is stopped for a long time, prevent rusting in the pump by taking out the transfer liquid in the pump and supplying grease, machine oil and others.

## MAKING CABITATION

- Lower the setting position of the pump as far as possible so as to increase the suction side liquid pressure. (Fig. 4.)
- Make the suction piping as short as possible.
- Use a little larger pipes as the suction pipe. (Fig. 5)
- When any suction hose is used, employ larger size by one step than the one of nominal size in general, i.e. the hose of the same I.D. as that for gas pipe. (Fig. 5)
- Air allowed into the suction pipe generates unusual noise and causes abrasion of the pump. Seal the joints of suction pipe completely.

Fig 4

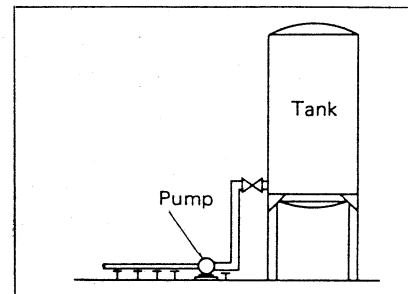
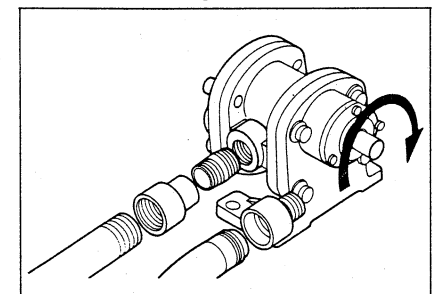
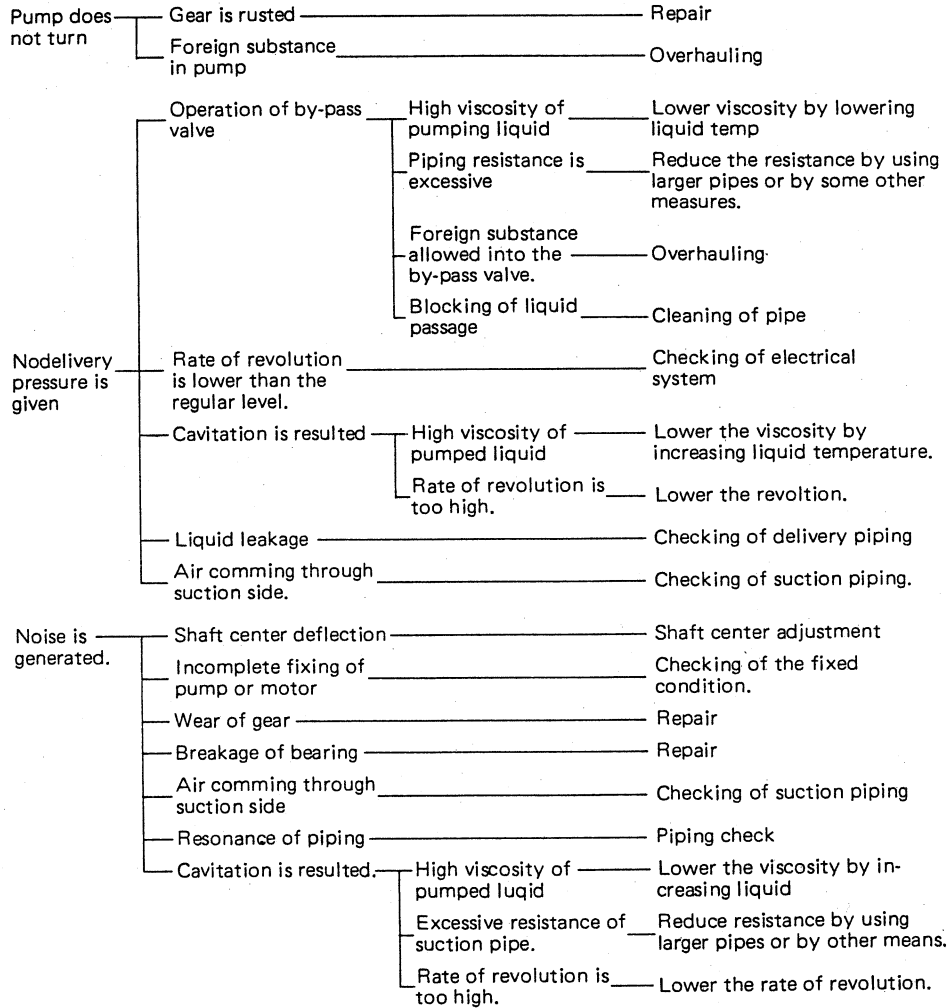

Fig 5



## TROUBLE & REMEDY



## SPECIFICATION

Pump	Curve No	Power	Connection Dia	Max Pressure	Deliyery volume		Coupling	Pump Shaft Dia		
					60Hz (1720rpm)	50Hz (1450rpm)				
GL-13-5	①	0.4kw4p 200V 3phase	PS13m/m (1/2")	0.5MPa	20 ℓ /min 5.3U.S.G./min	17 ℓ /min 4.5U.S.G./min	ZDC	φ18m/m		
GL-13-10	②	0.75kw4p 200V 3phase		1MPa						
GL-20-5	③	0.75kw4p 200V 3phase	PS20m/m (3/4")	0.5MPa	35 ℓ /min 9.2U.S.G./min	29 ℓ /min 7.7U.S.G./min				
GL-20-10	④	1.5kw4p 200V 3phase		1MPa						
GL-25-5	⑤	1.5kw4p 200V 3phase	PS25m/m (1")	0.5MPa	55 ℓ /min 14.5U.S.G./min	46 ℓ /min 12.1U.S.G./min				
GL-25-10	⑥	2.2kw4p 200V 3phase		1MPa						
GL-32-5	⑦	3.7kw4p 200V 3phase	PS32m/m (1 1/4")	0.5MPa	85 ℓ /min 22.4U.S.G./min	71 ℓ /min 18.7U.S.G./min				
GL-32-10	⑧			1MPa						
GL-40-5	⑨	2.2kw6p 200V 3phase	PS40m/m (1 1/2")	0.5MPa	123 ℓ /min 32.5U.S.G./min (1180rpm)	100 ℓ /min 26.4U.S.G./min (960rpm)			JIS	φ22m/m
GL-40-10	⑩	5.5kw6p 200V 3phase		1MPa						
GL-50-5	⑪	3.7kw6p 200V 3phase	PS50m/m (2")	0.5MPa	200 ℓ /min 52.8U.S.G./min (1160rpm)	165 ℓ /min 43.6U.S.G./min (940rpm)				
GL-50-10	⑫	7.5kw6p 200V 3phase		1MPa						

The specification is subject to change without notice for improvement.

## PERFORMANCE CURVE

