

KTH-S SERIES Operating Instructions & Parts Manual

Please read and save these instructions and Engine owner's manual. Read carefully before attempting to assemble, install, operate or maintain the product described.

Protect yourself and others by observing all safety information. Failure to comply with instructions could result in personal injury and or property damage! Retain instructions for future reference.

TRASH PUMP *Heavy Duty*

Description

Trash Pumps provide superior performance in dirty water applications.

All Trash Pumps have silicon carbide mechanical seals, high chrome cast impellers, and spheroid graphite ductile iron for longer durability. Honda Engines standard with oil alert are coupled with a lightweight aluminum die cast pump protected by a roll cage. Volutes are a spheroid cast graphite iron with high chrome impellers with silicon carbide mechanical seals for longer life and less maintenance. Self-priming up to 26 feet.

Applications are for dewatering construction, industrial and civil sites where the water contains larger solids of up to 1 1/2 inches.

In addition horizontally-fixing, front cover handle can fix lengthwise direction.

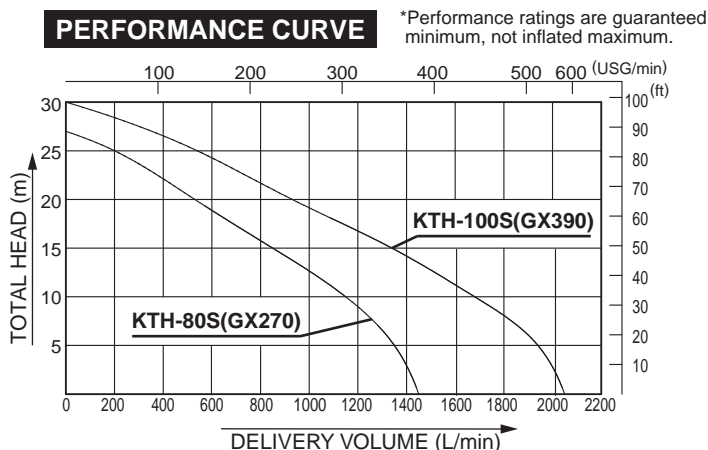
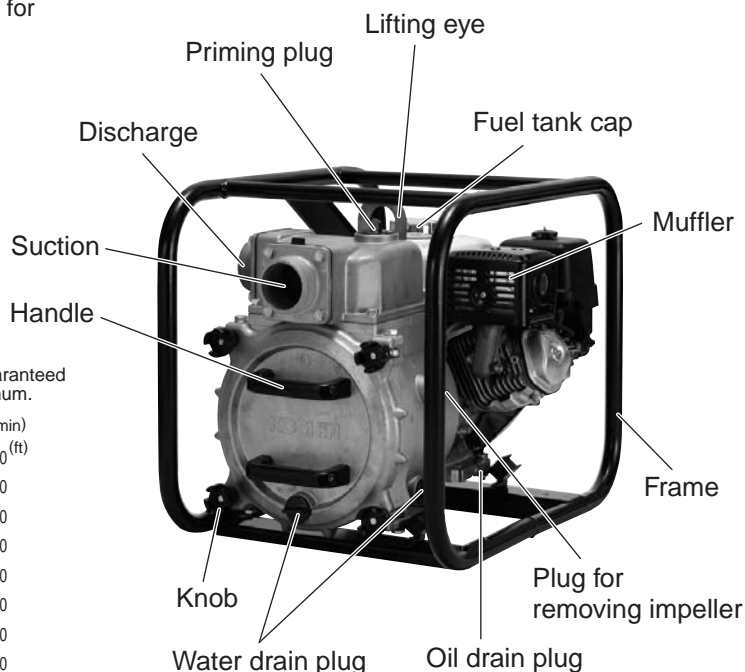

SPECIFICATIONS

Model		KTH-80S	KTH-100S
PUMP	Connection Dia	3" (80 mm)	4" (100 mm)
	Connection Thread	Parallel Pipe Thread or NPT	
	Total Head	27 m (89 ft)	30 m (98 ft)
	Discharge Volume	1450 L/min (383 USG/min)	2050 L/min (542 USG/min)
	Max. Suction Lift	8 m (26 ft)	
ENGINE	Type	Air Cooled 4 stroke OHV Gasoline Engine	
	Model	Honda GX270	Honda GX390
	Displacement	270 cm ³	389 cm ³
	Fuel	Automotive Unleaded Gasoline	
	Engine Oil	SAE 10W-30 API SJ or later, for general use.	
	Fuel Tank Capacity	5.3 L (1.4 USG)	6.1 L (1.6 USG)
	Starting System	Recoil starter	
Standard Accessory	None or 1 Strainer, 2 Hose Couplings, 3 Hose Bands, 1 Engine Tool Set		
Net Weight	66 kg (146 lbs)	82 kg (181 lbs)	
Guaranteed Sound Power	LWA 105 dB	LWA 106 dB	

ENGLISH

ESPAÑOL

FRANÇAIS

KOSHIN

TRASH PUMP

ENGLISH

This manual is prepared for your safety when operating pump. Please read carefully and comprehend fully before use. (Improper usage could cause injury or death.) Please keep this manual handy for future reference.

Unpacking

Upon receiving the pump it should be inspected for any damage and/or missing parts. If there is any damage, file a claim with the carrier who delivered the pump. Ensure the Pump Model is correct and keep all operating manuals with the pump for reference.

CAUTION

Do not operate unit if there is any damage due to shipping, handling, or use. Damage may cause injury or property damage.

Safety Precautions

Read these "Safety Precautions" before operation.

This manual contains information that is very important to know and understand. This information is provided for the SAFETY and to PREVENT EQUIPMENT PROBLEMS.

To help recognize this information, observe the following symbols:

DANGER

Indicates an imminently hazardous situation which, if not avoided, will result in death or serious injury.

WARNIG

Indicates a potentially hazardous situation which, if not avoided, could result in death or serious injury.

CAUTION

Indicates a potentially hazardous situation which, if not avoided, may result in minor or moderate injury, or property damage.

	DANGER
	Avoid open flames or spark when refueling or maintaining the pump or engine. Gasoline and vapors are highly flammable!
	Do not operate Engine pump inside a room or confined area without proper ventilation. Exhaust gases are dangerous. There is danger of gas poisoning.
	Do not use pump on slope. Fuel leakage at fuel tank or carburetor may cause fire.
	Keep area around the engine muffler free of debris—muffler can be very hot. It may cause fire or breakage.
	Read carefully and understand fully before use.
	Keep children away from pump when in operation.
	Do not overhaul, service or repair, except by a qualified person who is trained to do so.

	WARNIG
	This pump is designed to pump water. Not to be used for drinking water, chemicals, or flammable liquids.
	Water temperature range is 35°F/105°F (2°C/41°C). Damage may result if not followed.
	Do not run pump dry. This will cause premature wear and/or failure.
	Please use proper suction hose and connectors at suction side of pump.

CAUTION

Do not operate the pump without proper training. Know how to stop the pump quickly and understand the operation of all of the controls. Attach discharge hose before operating pump. Do not restrict or obstruct discharge hose.

Personal Safety

Wear eye protection at all times when operating or maintaining pumps. Keep area of operation clean, uncluttered and properly lighted; replace all unused tools and equipment. Must keep visitors at a safe distance from the area of operation.

TRASH PUMP *Heavy Duty*

Gasoline and its vapors are highly flammable.

- a. Use gasoline only.
- b. Only use an approved container to store gasoline.
- c. Keep gasoline away from heat, spark, or open flame.
- d. When working with gasoline, a fire extinguisher must be provided.
- e. When handling flammable liquid, adequate ventilation must be provided.
- f. Smoking is prohibited, when operating or fueling.

CAUTION

Make sure discharge hose is secure before operating the pump. A loose discharge hose may slip causing damage or personal injury. Do not overtighten threaded fittings. Check hoses and all connections before operation. Inspect pump and associated accessories before each use. Drain pump of water before servicing. Incorrect or improper usage could cause injury or death. Please keep this manual handy for future reference.

BEFORE USE

1. Make sure all accessories are provided.

List of accessories provided are printed on the pump manual.

2. 4-stroke engine needs "engine oil"

Refer to Figure 2 to check oil level. Fill engine oil as shown in illustration, at the bottom of engine.

Change oil every 8 hours for the first 20 hours and every 50 hours thereafter.

Applied oil: SAE#30 (spring-summer)

SAE#20 (autumn-winter)

SAE10W-30 (cold district, below-10°C)

Always check level of engine oil before each use. Use only Regular Unleaded Gasoline.

CAUTION

Low or no oil will prematurely damage engine. Warranty will not cover low oil situations.

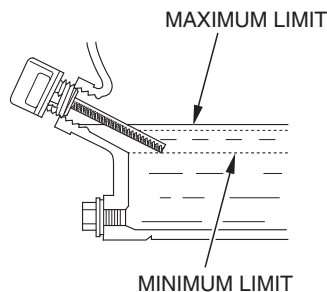
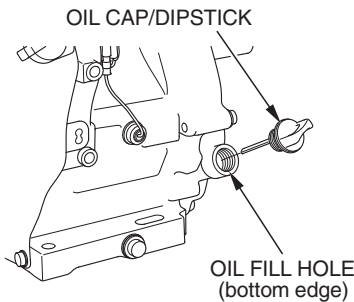

FIGURE 2

3. Please install coupling in order of: ① → ② → ③

Refer to Figure 3 while installing the coupling

If this coupling assembly is not installed correctly in accordance with Figure 3, it will leak and pump will fail to prime.

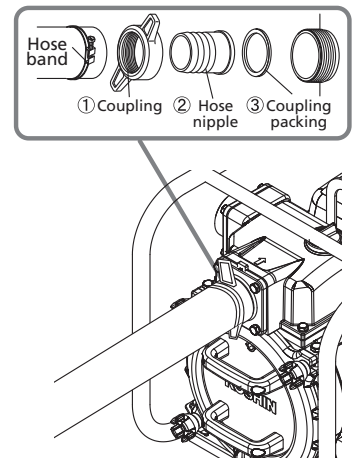

FIGURE 3

TRASH PUMP

4. Do not use a smaller diameter suction hose.

Using a smaller diameter hose will cause the pump to cavitate. Cavitation will result in pump failure.

5. Make sure suction hose is connected properly.

To avoid air leaks and slow priming, ensure the suction hose is connected properly.

CAUTION

If this step is not followed, the pump will fail to prime.

6. Ensure pump is fully filled with water

CAUTION

Dry running may cause serious damage or failure of the mechanical seal.

HOW TO USE

1. Ensure the pump casing is completely filled (primed) with liquid prior to start-up. Failure to properly prime the pump will result in pump damage.
2. Ensure strainer at the end of suction hose is fully submerged in water. If any mud or sand is at the bottom of water, suspend hose avoiding any debris.
3. Do not block, kink, or obstruct the flow of liquid through the discharge hose.

WARNING

- 1) *Do not dead head or restrict water flow either at suction or discharge side of the pump. This may cause high air pressure and / or high temperature conditions within the pump. Extreme heat or pressure may exist.*
- 2) *When priming the pump, only use water. If long priming times - 5 min or more, turn off engine and allow pump to cool off.*
- 3) *Do not open plugs or hoses if heat or pressure exists within the pump.*

CAUTION

Beware of water hammering
Do not allow any vehicle to run over the delivery hose. Do not close the delivery valve abruptly because water-hammer may occur. This may result in excessive damage to the pump.

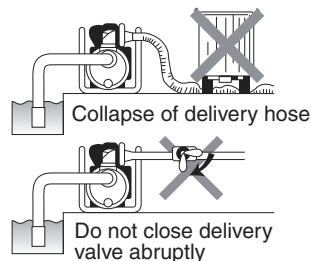

For engine instructions and notes, please refer to the Engine Operation Manual enclosed.

AFTER USE

After use, remove the drain plug at the bottom and pour water from the suction/discharge ports so that the remaining sand is forced out of the pump. If the pump is used to transfer muddy water over a long period of time, a large volume of sand will pile up in the pump casing, making it difficult to remove the front cover. Therefore, clean the inside of the pump periodically.

CAUTION

Water left in the pump may freeze in winter and damage pump.
After use and before storage drain water by removing drain plug.

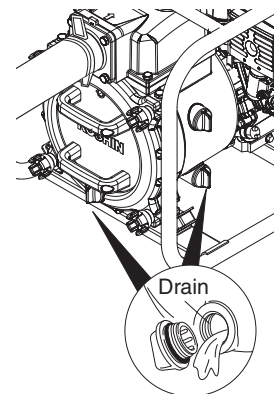

For long storage

Completely drain all fuel from the fuel tank and carburetor. Unused fuel in tank (if kept more than 30 days) may result in engine failure. *Please refer to the Engine Operation Manual.

CAUTION

Do not smoke or expose to open flame or spark as fuel is highly flammable. Unused fuel must not remain in the tank for long-term storage. Unused, older fuel may cause future engine failure.

TRASH PUMP *Heavy Duty*

Troubleshooting

SYMPTOM	POSSIBLE CAUSE(S)	CORRECTIVE ACTION
Cannot pull or hard to pull recoil starter	<ol style="list-style-type: none"> 1. Old fuel 2. Rusting inside engine 3. Burn out of engine 4. Blocked impeller 5. Debris at impeller 	<ol style="list-style-type: none"> 1. Replace fuel. If there is no improvement, repair engine 2. Refer to Engine Operation Manual. (Repair) 3. Refer to Engine Operation Manual. (Repair) 4. Dismantle & clean the impeller 5. Dismantle & clean the impeller <div style="text-align: right;">⇒ SOLUTION ①</div>
Low delivery volume	<ol style="list-style-type: none"> 1. Air leakage from suction side 2. Output power down from engine 3. Damage of mechanical seal 4. Suction lift is high 5. Suction pipe is too long or too small in diameter 6. Water leaking from delivery hose or pipe 7. Debris at impeller 8. Worn or broken impeller 	<ol style="list-style-type: none"> 1. Check hose at suction side 2. Check and repair engine 3. Replace mechanical seal (Repair) 4. Decrease suction lift 5. Shorten suction pipe or enlarge repair to proper diameter 6. Check and stop leakage of water 7. Dismantle & clean the impeller 8. Replace the impeller (Repair) <div style="text-align: right;">⇒ SOLUTION ②</div> <div style="text-align: right;">⇒ SOLUTION ①</div>
Pump does not prime water	<ol style="list-style-type: none"> 1. Air leaking in from suction side 2. Insufficient priming water Inside pump casing 3. Drain plug is not tightened 4. Engine speed/rpm is too low 5. Damage of mechanical seal 6. Wrong suction hose used 	<ol style="list-style-type: none"> 1. Check hose and connections at suction side 2. Fill pump with water for priming Refer to BEFORE USE - "5 Fill pump with water before use" 3. Tighten drain plug firmly. Please refer to "ATTENTION AFTER USE" 4. Refer to Engine Operation Manual 5. Replace mechanical seal (Repair) 6. Use correct suction hose <div style="text-align: right;">⇒ SOLUTION ②</div>
Engine does not start	<ol style="list-style-type: none"> 1. Carburetor is choked/blocked 2. Spark Plug is wet 3. Air cleaner dirty 4. Too much engine oil (4-cycle engine) 5. Insufficient engine oil (4-stroke engine) 6. After checking above points, still engine does not start 	<ol style="list-style-type: none"> 1. Repair 2. Check & repair the plug 3. Clean air cleaner. (Refer to Engine Operation Manual) 4. Adjust engine oil to suitable level 5. Function of oil alert (oil sensor) is working. (This function protects engine. If volume of engine oil is not a suitable level, engine does not start) 6. Possibility of damage, inner parts of engine (Repair) <div style="text-align: right;">⇒ SOLUTION ③</div>
Oil leakage from muffler or air cleaner	<ol style="list-style-type: none"> 1. Tipping of engine 	<ol style="list-style-type: none"> 1. Clean engine (Air Cleaner, Carburetor, Muffler, Spark plug, etc.)

TRASH PUMP

ENGLISH

SOLUTION ①

Remove front cover and clean debris from impeller and interior.

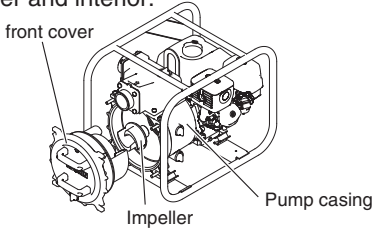

SOLUTION ②

Check suction hose. In case of no suction or small delivery, the cause is usually due to air leakage at suction side. In such case:

1. Remove suction hose.

2. Start engine with water inside the pump.

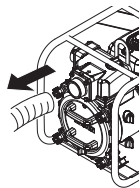

3. Press the palm of your hand to cover the suction hole and wait 30 seconds. If you feel suction on your palm, the pump is working fine but hose connection needs correction.

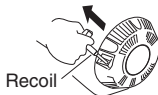

Test for suction

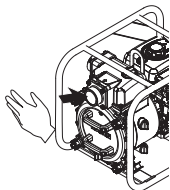

4. Please check if rubber/gasket packing is installed and there is any hole in suction hose.

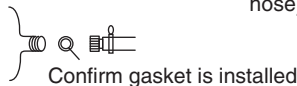
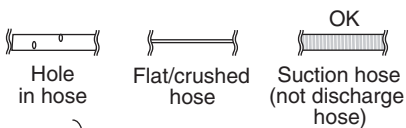

SOLUTION ③

Confirm the spark plug is clean and free of debris. Otherwise use clean cloth to remove stains and dirt.

Confirm gap between spark plug. Plug gap should be 0.6-0.7 mm or 0.024-0.028 in. Adjust gap to be within this range.

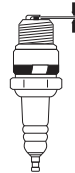

New spark plug may be required if engine still will not start after you clean plug and adjust gap of plug.

CAUTION

There are many different types of spark plugs. Please check and select correct plugs according to Engine Operation Manual.

NOTE: A leak between the pump casing and the engine is usually due to a damaged mechanical seal. Refer to a local service center.

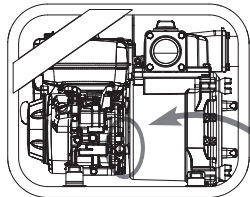

CAUTION

For assistance with checking and repair, please ask your nearest sales store for after sales service.

MAINTENANCE

Mechanical seal replacement

1. Remove knobs by turning counterclock-wise. Pull handle towards you to remove both front cover and volute casing.



2. Remove impeller plug. Place a stick thru hole against impeller, hammer on stick to loosen impeller. Unscrew hexagon head in center of impeller.



3. Remove mechanical seal from impeller.



TRASH PUMP *Heavy Duty*

4. Remove mechanical seal from the pump casing using two flat head screwdrivers.

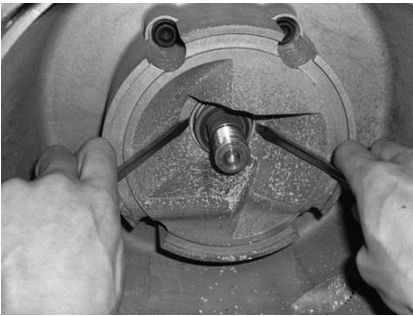

5. Set new mechanical seal into the pump casing keeping the face of the seal clean. Install the mechanical seal into the impeller with adjusting washers.

CAUTION

Keep the face of the seal clean.

6. Install the mechanical seal over engine shaft keeping the seal faces clean.
7. Replace the impeller adjusting washers, the same quantity as removed.



CAUTION

Be sure seal is set fully and correctly.

8. Install the impeller, and then tighten in a clockwise direction by hand.
9. Tighten the impeller by hitting with a soft hammer in a clockwise direction. The impeller should be tighten enough so that it cannot be loosened by hand.
10. Install the front cover (with volute casing) in the correct position on the pump casing with O-Ring correctly placed.
11. Correctly install the front cover and evenly tighten the right and left knobs.

CAUTION

Ensure all Packings/Gaskets are installed.

TRASH PUMP

ENGLISH

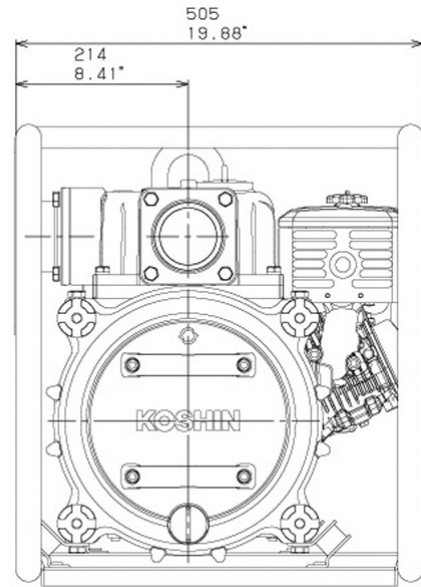
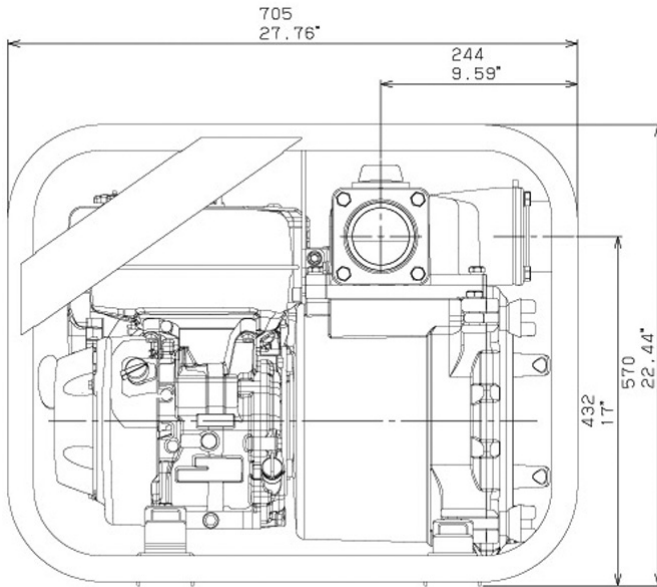

KTH-80S

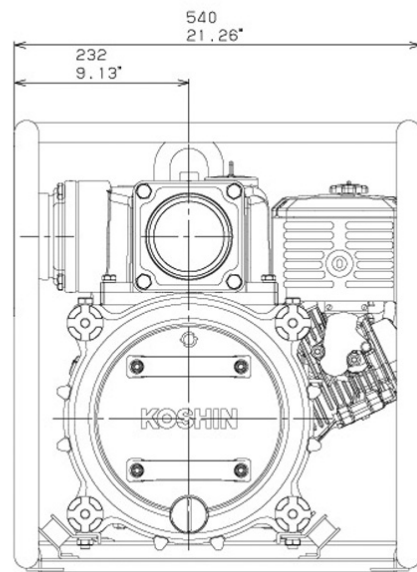
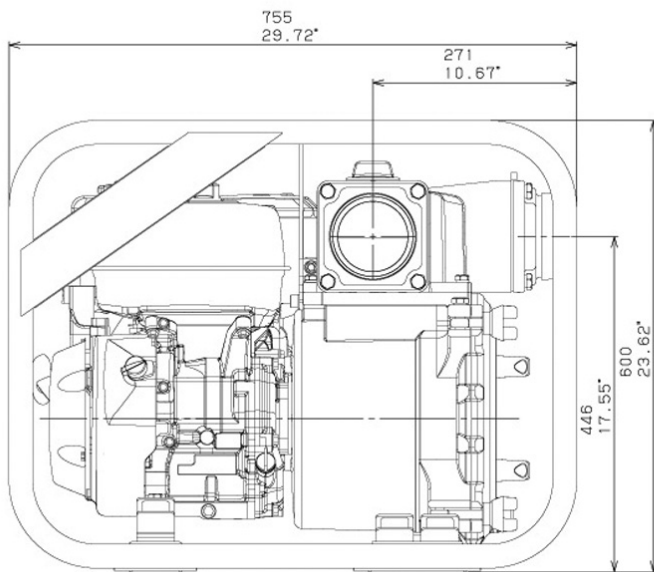

KTH-100S

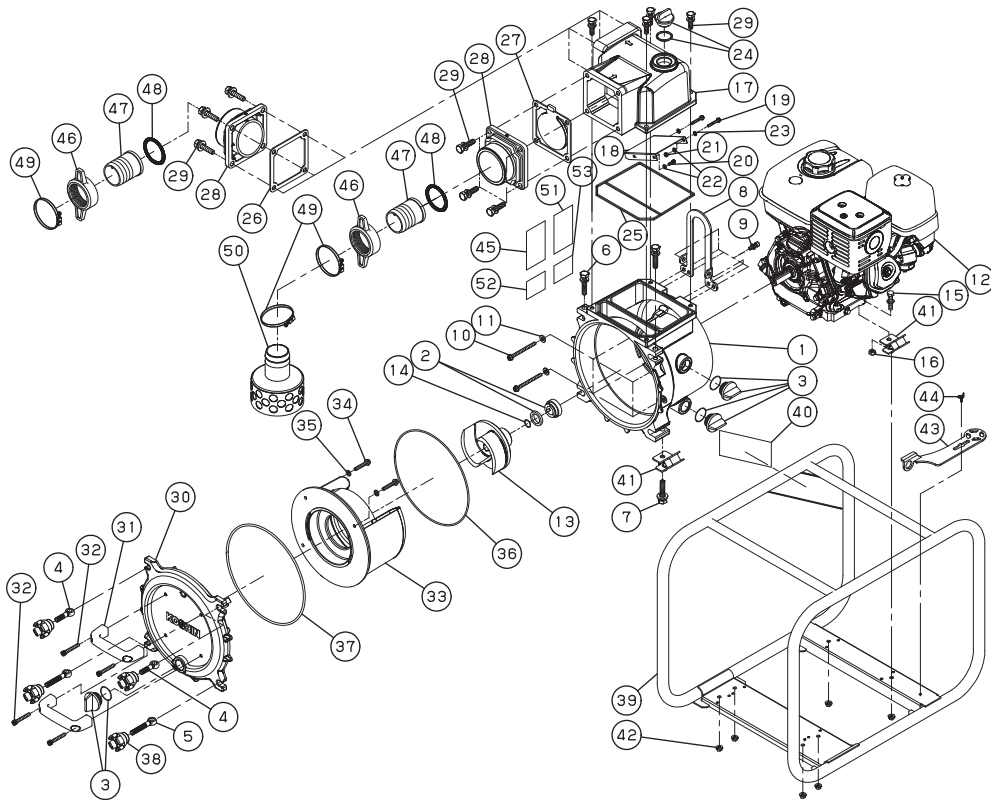

KTH-80S

No.	PARTS CODE	PARTS NAME	QTY	OTHER
1	0121439	Pump case	1	
2	0115678	Mechanical seal	1	
3	0118079	Plug 25A SET	3	
4	0121843	Cover bolt-S	2	
5	0121844	Cover bolt-L	2	
6	743119083	Hexagon head screw with captive spring washer M12x45	2	
7	743119084	Hexagon head screw with captive spring washer M12x50	2	
8	0121454	Hookplate	1	
9	734614090	Hexagon socket head cap screw with spring washer M10x25	6	
10	0121925	Hexagon socket head cap screw with flange M10x1.25x50	4	
11	0121915	Aluminum washer φ10	4	
12	N/A	GX270UT2 engine	1	
13	0121438	Impeller	1	
14	0110081	Impeller adjustment washer T0.3	3	
15	743119067	Hexagon head screw with captive spring washer M10x40	2	
16	827419010	Hexagon nut M10	2	
17	0121437	Separate head	1	
18	0121457	Baffle	1	
19	734705047	Hexagon socket head cap screw with flange M6x16	2	
20	734505276	Hexagon socket head cap screw M6x8	2	
21	827405006	Hexagon nut M6	2	
22	846205006	Washer φ6	4	
23	0121914	Aluminum washer φ6	2	
24	0118450	Plug 32A SET	1	
25	0121450	Head packing	1	
26	0110584	Flange packing	1	
27	0121574	Check valve	1	
28	0115837	Discharge flange NPT3	2	BAA
	0115838	Discharge flange G3	2	BAB
29	743119063	Hexagon head screw with captive spring washer M12x35	12	
30	0121440	Front cover	1	

No.	PARTS CODE	PARTS NAME	QTY	OTHER
31	0121453	Handle	2	
32	734520070	Hexagon socket head cap screw M8x35	4	
33	0121441	Volute case	1	
34	734705066	Hexagon socket head cap screw with flange M8x25	3	
35	0116493	Aluminum washer φ8	3	
36	0121917	O-ring G283x3.55	1	
37	0121916	O-ring G295x5.3	1	
38	0121449	Knob	4	
39	0128438	Base ASSY	1	
40	0121435	Label, Side panel	1	
41	0116172	Rubber cushion	4	
42	842319008	Hexagon nut with spring lock washer M8	4	
43	0121918	Multi tool	1	
44	741305153	Wing bolt M8x15	1	
45	0121927	Name plate KTH-80S-BAA	1	BAA
	0121445	Name plate KTH-80S-BAB	1	BAB
46	0110300	Coupling G3	2	BAB only
47	0111931	Nipple	2	BAB only
48	0110100	Coupling packing	2	BAB only
49	940407090	Hose band	3	BAB only
50	0110978	Strainer nipple	1	BAB only
51	0114713	Label, CAUTION	1	BAB only
52	0114718	Label, CE mark	1	BAB only
53	0116283	Label, EU noise 105	1	BAB only
	0114820	EC Declaration of conformity	1	BAB only

ENGLISH

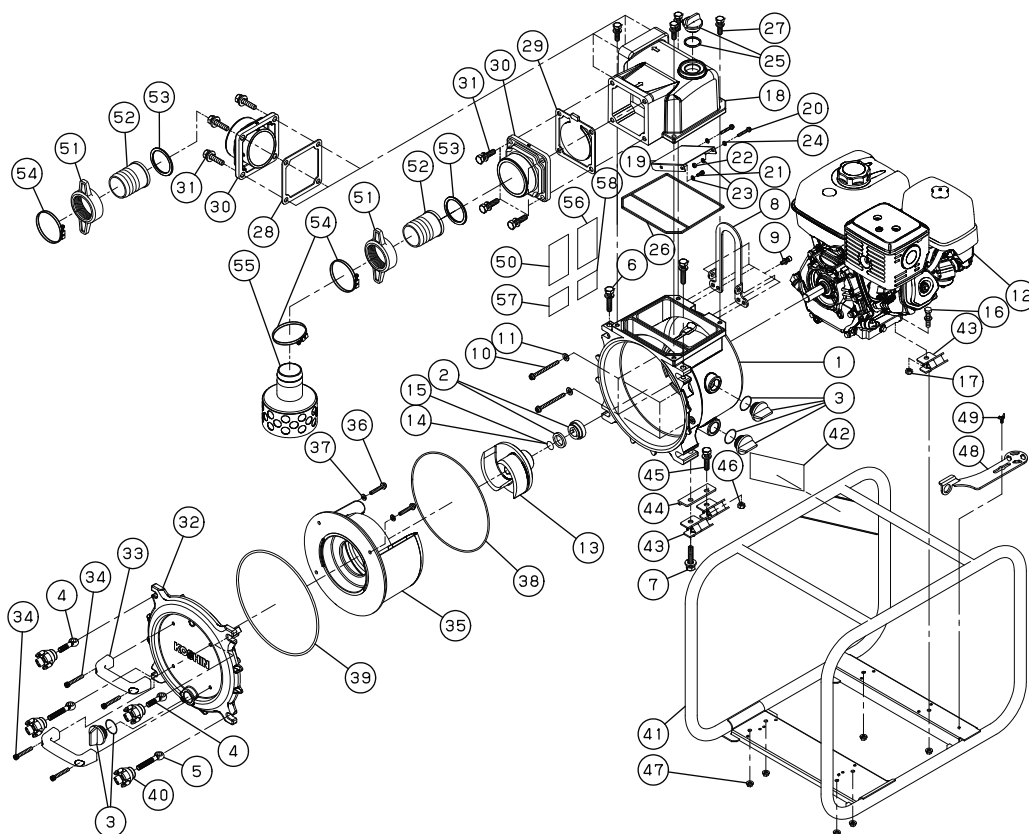

KTH-100S

No.	PARTS CODE	PARTS NAME	QTY	OTHER
1	0121442	Pump case	1	
2	0115678	Mechanical seal	1	
3	0118079	Plug 25A SET	3	
4	0121843	Cover bolt-S	2	
5	0121844	Cover bolt-L	2	
6	743119083	Hexagon head screw with captive spring washer M12x45	2	
7	743119085	Hexagon head screw with captive spring washer M12x55	2	
8	0121455	Hookplate	1	
9	734614090	Hexagon socket head cap screw with spring washer M10x25	6	
10	0121925	Hexagon socket head cap screw with flange M10x1.25x50	4	
11	0121915	Aluminum washer φ10	4	
12	N/A	GX390UT2 engine	1	
13	0121436	Impeller	1	
14	0110561	Impeller adjustment washer T0.3	3	
15	0116405	Impeller adjustment washer T0.1	3	
16	743119067	Hexagon head screw with captive spring washer M10x40	2	
17	827419010	Hexagon nut M10	2	
18	0121452	Separate head	1	
19	0121832	Baffle	1	
20	734705047	Hexagon socket head cap screw with flange M6x16	2	
21	734505276	Hexagon socket head cap screw M6x8	2	
22	827405006	Hexagon nut M6	2	
23	846205006	Washer φ6	4	
24	0121914	Aluminum washer φ6	2	
25	0118450	Plug 32A SET	1	
26	0121450	Head packing	1	
27	743119063	Hexagon head screw with captive spring washer M10x30	4	
28	0110750	Flange packing	1	
29	0121577	Check valve	1	
30	0111365	Suction flange NPT4	2	BAA
	0116188	Suction flange G4	2	BAB

No.	PARTS CODE	PARTS NAME	QTY	OTHER
31	743119080	Hexagon head screw with captive spring washer M12x35	8	
32	0121443	Front cover	1	
33	0121453	Handle	2	
34	734520070	Hexagon socket head cap screw M8x35	4	
35	0121444	Volute case	1	
36	734705066	Hexagon socket head cap screw with flange M8x25	3	
37	0116493	Aluminum washer φ8	3	
38	0121917	O-ring G283x3.55	1	
39	0121916	O-ring G295x5.3	1	
40	0121449	Knob	4	
41	0128440	Base ASSY	1	
42	0121435	Label, Side panel	1	
43	0116172	Rubber cushion	6	
44	0116273	Mount, rubber cushion	2	
45	743119076	Hexagon head screw with captive spring washer M12x25	2	
46	827419012	Hexagon nut M12	2	
47	842319008	Hexagon nut with spring lock washer M8	6	
48	0121919	Multi tool	1	
49	741305153	Wing bolt M8x15	1	
50	0121928	Name plate KTH-100S-BAA	1	BAA
	0121446	Name plate KTH-100S-BAB	1	BAB
51	0116189	Coupling G4	2	BAB only
52	0110471	Nipple	2	BAB only
53	0111478	Coupling packing	2	BAB only
54	940407120	Hose band	3	BAB only
55	0110979	Strainer nipple	1	BAB only
56	0114713	Label, CAUTION	1	BAB only
57	0114718	Label, CE mark	1	BAB only
58	0116412	Label, EU noise 106	1	BAB only
	0114820	EC Declaration of conformity	1	BAB only

Por favor, lea y guarde este manual de instrucciones y el manual del propietario del motor. Léalo minuciosamente antes de intentar montar, instalar operar y efectuar el mantenimiento del producto que se describe. Protéjase usted mismo y a los demás respetando toda la información de seguridad. ¡Si no sigue las instrucciones correrá el peligro de sufrir heridas personales o de ocasionar daños materiales! Conserve este manual de instrucciones para poder consultarlo cuando sea necesario.

BOMBA DE RESIDUOS *Trabajos pesados*

Descripción

Las bombas de residuos ofrecen un desempeño superior en aplicaciones de aguas sucias. Todas las bombas de residuos tienen sellos mecánicos de carburo de silicio, impulsores fundidos en alto cromo así como hierro dúctil con grafito esferoidal para conseguir mayor durabilidad. Los motores Honda estándar con alerta de aceite están conectados a una bomba fundida a presión en aluminio de bajo peso protegida por una jaula que la rodea completamente. Las volutas son de hierro fundido con grafito esferoidal con impulsores de alto cromo y sellos mecánicos de carburo de silicio para ofrecer una vida de servicio más larga y menos mantenimiento. Cebado automático hasta 26 pies (8 m).

Las aplicaciones son para desagüe de sitios de construcción, industriales y civiles, en los que el agua contiene residuos sólidos más grandes de hasta 1-1/2 pulgadas (38 mm).

Además de su fijación horizontal, el asa de la cubierta frontal puede fijarse en el sentido longitudinal.

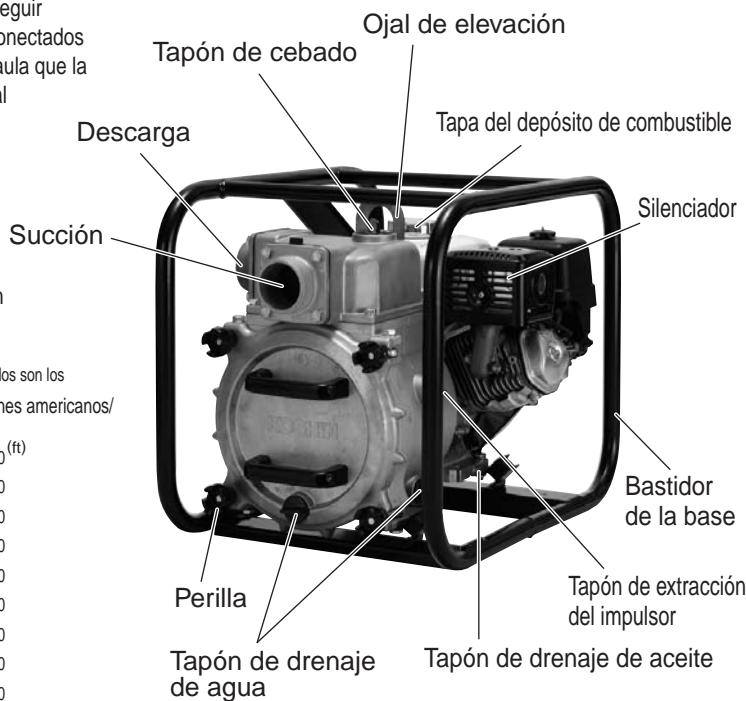

Modelo: KTH-80S

CURVA DE RENDIMIENTO

*Los valores de rendimiento garantizados son los mínimos y no los máximos. (Galones americanos/min.)

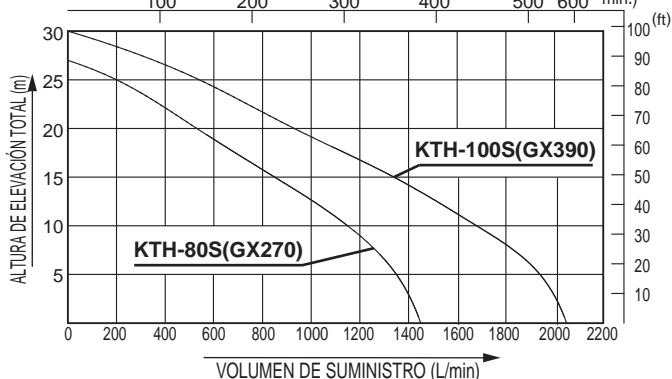

ESPECIFICACIONES

Model		KTH-80S	KTH-100S
BOMBA	Diámetro de conexión	80 mm (3")	100 mm (4")
	Rosca de conexión	Rosca de tubo paralela o NPT	
	Altura de elevación total	27 m (89 pies)	30 m (98 pies)
	Volumen de descarga	1450 L/min (383 galones americanos/min)	2050 L/min (542 galones americanos/min)
	Elevación de succión máx.	8 m (26 pies)	
MOTOR	Tipo	Motor de gasolina OHV de 4 tiempo enfriado por aire	
	Modelo	Honda GX270	Honda GX390
	Cilindrada	270 cm ³	389 cm ³
	Combustible	Gasolina sin plomo para automóviles	
	Aceite de motor	SAE 10W-30, API SJ o posterior para aplicaciones generales	
	Capacidad del depósito de combustible	5.3 L	6.1 L
	Sistema de arranque	Arrancador manual retráctil	
Accesorios estándar	Ninguno o 1 colador, 2 acoples de manguera, 3 bandas de manguera, 1 juego de herramientas del motor		
Peso neto	66 kg (146 lbs)	82 kg (181 lbs)	
Potencia sonora garantizada	LWA 105 dB	LWA 106 dB	

BOMBA DE RESIDUOS

This manual is prepared for your safety when operating pump. Please read carefully and comprehend fully before use. (Wrong usage could cause injury or death.) Please keep this manual handy for future reference.

Unpacking

Upon receiving the pump it should be inspected for any damage and/or missing parts. If there is any damage, file a claim with the carrier who delivered the pump. Ensure the Pump Model is correct and keep all operating manuals with the pump for reference.

CAUTION

Do not operate unit if there is any damage due to shipping, handling, or use. Damage may cause injury or property damage.

Safety Precautions

Read these "Safety Precautions" before operation.

This manual contains information that is very important to know and understand. This information is provided for the SAFETY and to PREVENT EQUIPMENT PROBLEMS.

To help recognize this information, observe the following symbols:

DANGER

















Indicates an imminently hazardous situation which, if not avoided, will result in death or serious injury.









WARNIG

Indicates a potentially hazardous situation which, if not avoided, could result in death or serious injury.

CAUTION

Indicates a potentially hazardous situation which, if not avoided, may result in minor or moderate injury, or property damage.

 DANGER
 <p>Avoid open flames or spark when refueling or maintaining the pump or engine.</p>  <p>Gasoline and vapors are highly flammable!</p>
 <p>Do not operate Engine pump inside a room or confined area without proper ventilation.</p>  <p>Exhaust gases are dangerous. There is danger of gas poisoning.</p> 
 <p>Do not use pump on slope. Fuel leakage at fuel tank or carburetor may cause fire.</p> 
 <p>Keep area around the engine muffler free of debris—muffler can be very hot. It may cause fire or breakage.</p> 
 <p>Read carefully and understand fully before use.</p> 
 <p>Keep children away from pump when in operation.</p> 
 <p>Do not overhaul, service or repair, except by a qualified person who is trained to do so.</p> 

 WARNIG
 <p>This pump is designed to pump water. Not to be used for drinking water, chemicals, or flammable liquids.</p> 
 <p>Water temperature range is 35°F/105°F (2°C/41°C). Damage may result if not followed.</p> 
 <p>Do not run pump dry. This will cause premature wear and/or failure.</p> 
 <p>Please use proper suction hose and connectors at suction side of pump.</p> 

CAUTION

Do not operate the pump without proper training. Know how to stop the pump quickly and understand the operation of all of the controls. Attach discharge hose before operating pump. Do not restrict or obstruct discharge hose.

Personal Safety

Wear eye protection at all times when operating or maintaining pumps. Keep area of operation clean, uncluttered and properly lighted; replace all unused tools and equipment. Must keep visitors at a safe distance from the area of operation.

BOMBA DE RESIDUOS *Trabajos pesados*

La gasolina y sus vapores son muy inflamables.

- Utilice únicamente gasolina.
- Utilice únicamente un recipiente homologado para almacenar la gasolina.
- Mantenga la gasolina alejada del calor, chispas o llamas descubiertas.
- Cuando trabaje con gasolina deberá tener a mano un extintor de incendios.
- Cuando manipule líquidos inflamables deberá proporcionar una ventilación adecuada.
- Se prohíbe fumar.

PRECAUCIÓN

Asegúrese de que la manguera de descarga esté asegurada antes de operar la bomba. Una manguera de descarga suelta puede resbalar y causar daños o heridas personales.

No apriete excesivamente los acoples roscados.

Verifique las mangueras y todas las conexiones antes de la operación.

Inspeccione la bomba y los accesorios asociados antes de cada uso.

Drene el agua de la bomba antes de llevar a cabo el servicio.

La utilización incorrecta o inapropiada podría ocasionar heridas o incluso la muerte.

Guarde este manual en un lugar accesible para poder consultarlo en el futuro.

ANTES DE LA UTILIZACIÓN

1. Asegúrese de que no falte ninguno de los accesorios.

La lista de accesorios suministrados está impresa en el manual de la bomba.

2. Los motores de 4 tiempos necesitan "aceite de motor"

Consulte la Figura 4 para verificar el nivel de aceite.

Llene aceite de motor por el puerto del aceite, como se muestra en la ilustración, situado en la parte inferior del motor.

Cambie el aceite cada 8 horas durante las primeras 20 horas y después hágalo cada 50 horas.

Aceite aplicado: SAE#30

(primavera-verano)

SAE#20 (otoño-invierno)

SAE 10W-30 (regiones frías, por debajo de -10 °C)

Verifique siempre el nivel del aceite de motor antes de cada utilización. Utilice únicamente gasolina normal sin plomo.

PRECAUCIÓN

Un nivel bajo o la falta de aceite causará daños prematuros en el motor. Estos casos de insuficiencia de aceite no quedan cubiertos por la garantía.

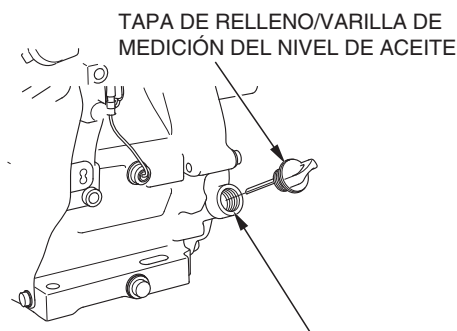

ORIFICIO DE RELLENO DE ACEITE (borde inferior)

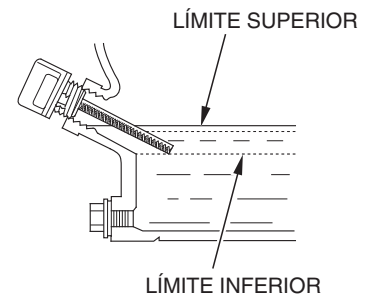

3. Instale los acoples en el orden siguiente: ① → ② → ③

Mientras instale los acoples, consulte la Figura 5.

Si este conjunto de acoples no se instala correctamente según la Figura 5, se producirán fugas y la bomba dejará de cebar.

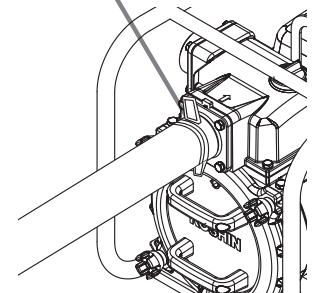
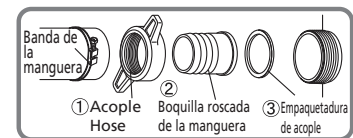

BOMBA DE RESIDUOS

4. No utilice una manguera de succión de diámetro menor.

La utilización de una manguera de diámetro menor ocasionará aspiraciones en vacío de la bomba. La aspiración en vacío ocasiona fallas del sello mecánico.

5. Asegúrese de que la manguera de succión esté conectada de manera adecuada.

Para evitar fugas de aire y un cebado lento, asegúrese de que la manguera de succión esté conectada de manera adecuada.

⚠ PRECAUCIÓN

Si no se sigue este paso, la bomba no cebará.

6. Ensure pump is fully filled up with water

⚠ PRECAUCIÓN

El funcionamiento en seco puede causar serios daños o fallas del sello mecánico.

MODO DE UTILIZACIÓN

1. Asegúrese de que el alojamiento de la bomba esté completamente lleno (cebado) de líquido antes de arrancar. Si no se ceba adecuadamente la bomba se producirán daños en la bomba.
2. Asegúrese de que el filtro tipo malla que hay en el extremo de la manguera de succión esté completamente sumergido en el agua. Si hay lodo o arena en el fondo del agua, suspenda la manguera para evitar los escombros.
3. No bloquee, doble ni obstruya el flujo del líquido que pasa a través de la manguera de descarga.

⚠ PRECAUCIÓN

Tenga cuidado con los golpes de ariete del agua.

No permita que ningún vehículo pase por encima de la manguera de salida.

No cierre la válvula de salida de manera abrupta porque podrían producirse golpes de ariete del agua. Esto podría ocasionar daños excesivos en la bomba.

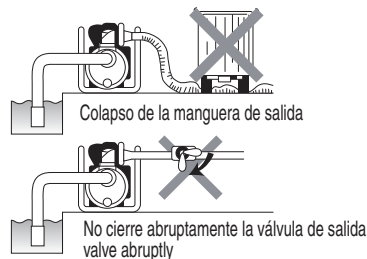

Para ver las instrucciones y notas acerca del motor, consulte el Manual de operación del motor adjunto.

DESPUÉS DE LA UTILIZACIÓN

Después de la utilización de la bomba, quite el tapón de drenaje de la parte inferior e introduzca agua desde los puertos de succión/descarga de modo que se fuerce la salida de la arena remanente al exterior de la bomba. Si se utiliza la bomba para la transferencia de agua turbia durante mucho tiempo, se acumulará una gran cantidad de arena en el alojamiento de la bomba, lo cual dificultará la extracción de la cubierta frontal. Por lo tanto, limpie periódicamente el interior de la bomba.

⚠ PRECAUCIÓN

Water inside may freeze at below 0°C in winter and may damage pump. After use, drain water from drain plug before storing.

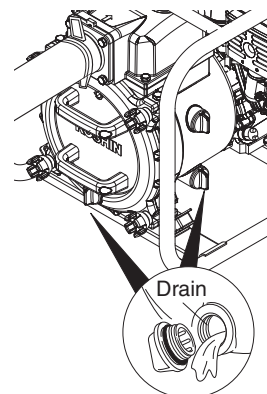

Almacenaje durante períodos largos

Drene por completo el combustible del tanque de combustible y del carburador. El combustible no utilizado que queda en el tanque (si se conserva durante más de 30 días) puede ocasionar daños en el motor. *Consulte el Manual de operación del motor.

⚠ PRECAUCIÓN

No fumar ni exponer a llamas abiertas o chispas porque el combustible es muy inflamable.

El combustible no utilizado no deberá dejarse en el tanque durante el almacenamiento durante períodos prolongados. El combustible no utilizado y pasado puede causar en el futuro averías del motor.

BOMBA DE RESIDUOS *Trabajos pesados*

Troubleshooting

SYMPTOM	POSSIBLE CAUSE(S)	CORRECTIVE ACTION
Cannot pull or hard to pull recoil starter	<ol style="list-style-type: none"> 1. Old fuel 2. Rusting inside engine 3. Burn out of engine 4. Blocked impeller 5. Debris at impeller 	<ol style="list-style-type: none"> 1. Replace fuel. If there is no improvement, repair engine 2. Refer to Engine Operation Manual. (Repair) 3. Refer to Engine Operation Manual. (Repair) 4. Dismantle & clean the impeller ⇒ SOLUTION ① 5. Dismantle & clean the impeller
Low delivery volume	<ol style="list-style-type: none"> 1. Air leakage from suction side 2. Output power down from engine 3. Damage of mechanical seal 4. Suction lift is high 5. Suction pipe is too long or too small in diameter 6. Water leaking from delivery hose or pipe 7. Debris at impeller 8. Worn or broken impeller 	<ol style="list-style-type: none"> 1. Check hose at suction side ⇒ SOLUTION ② 2. Check and repair engine 3. Replace mechanical seal (Repair) 4. Decrease suction lift 5. Shorten suction pipe or enlarge repair to proper diameter 6. Check and stop leakage of water 7. Dismantle & clean the impeller ⇒ SOLUTION ① 8. Replace the impeller (Repair)
Pump does not prime water	<ol style="list-style-type: none"> 1. Air leaking in from suction side 2. Insufficient priming water Inside pump casing 3. Drain plug is not tightened 4. Engine speed/rpm is too low 5. Damage of mechanical seal (NOTE) 6. Wrong suction hose used 	<ol style="list-style-type: none"> 1. Check hose and connections ⇒ SOLUTION ② at suction side 2. Fill pump with water for priming Refer to BEFORE USE - "5 Fill pump with water before use" 3. Tighten drain plug firmly. Please refer to "ATTENTION AFTER USE" 4. Refer to Engine Operation Manual 5. Replace mechanical seal (Repair) 6. Use suction hose correctly
Engine does not start	<ol style="list-style-type: none"> 1. Carburetor is choked/blocked 2. Spark Plug is wet 3. Air cleaner dirty 4. Too much engine oil (4-cycle engine) 5. Insufficient engine oil (4-stroke engine) 6. After checking above points, still engine does not start 	<ol style="list-style-type: none"> 1. Repair ⇒ SOLUTION ③ 2. Check & repair the plug 3. Clean air cleaner. (Refer to Engine Operation Manual) 4. Adjust engine oil to suitable level 5. Function of oil alert (oil sensor) is working. (This function protects engine. If volume of engine oil is not a suitable level, engine does not start) 6. Possibility of damage, inner parts of engine (Repair)
Oil leakage from muffler or air cleaner	<ol style="list-style-type: none"> 1. Tipping of engine 	<ol style="list-style-type: none"> 1. Clean engine (Air Cleaner, Carburetor, Muffler, Spark plug, etc.)

BOMBA DE RESIDUOS

SOLUCIÓN ①

Quite la cubierta frontal y limpie la suciedad del impulsor.

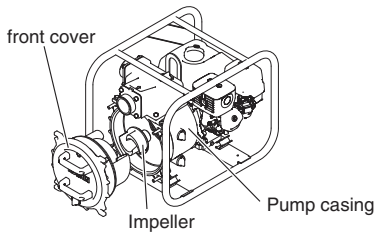

SOLUCIÓN ②

Verifique la manguera de succión. En el caso de no producirse succión o salida insuficiente, la causa reside normalmente en fugas de aire en el lado de succión. En tales casos:

1. Extraiga la manguera de succión.

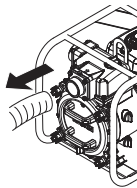

2. Arranque el motor con agua en el interior de la bomba.

3. Presione con la palma de la mano para taponar el orificio de succión y espere 30 segundos. Si nota succión en la palma de la mano, significa que la bomba funciona bien pero que es necesario corregir las conexiones de manguera.

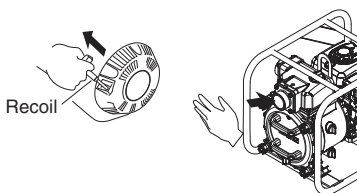

4. Revise si la empaquetadura de goma/empaque de la junta está instalado y si hay algún agujero en la manguera de succión.

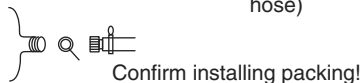
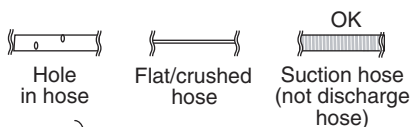

SOLUCIÓN ③

Confirme que la bujía esté limpia y exenta de suciedad. Si no lo está, utilice un paño limpio para sacar las manchas y la suciedad.

Confirme que el huelgo de la bujía. El huelgo de la bujía deberá ser de 0,6-0,7 mm o 0,024-0,028 pulgadas. Ajuste el huelgo para que quede dentro de este rango.

Es posible que necesite una bujía nueva si el motor no arranca después de haber limpiado la bujía y de haber ajustado su huelgo.

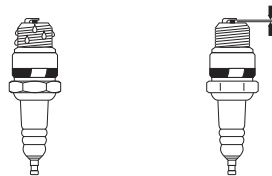

PRECAUCIÓN

Hay muchos tipos distintos de bujías. Verifique y seleccione las bujías correctas según se indica en el Manual de operación del motor.

NOTA: Las fugas entre el alojamiento de la bomba y el motor se deben normalmente a un sello mecánico dañado. Consulte a un centro de servicio local.

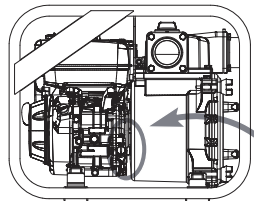

PRECAUCIÓN

Para recibir asistencia para las revisiones y reparaciones, pregunte en el centro de ventas más cercano acerca del servicio postventa.

MANTENIMIENTO

Sustitución del sello mecánico

1. Gire la perilla hacia la izquierda y extraiga la perilla.

Tire del asa hacia usted y entonces podrá retirar la cubierta frontal y el alojamiento de las volutas.

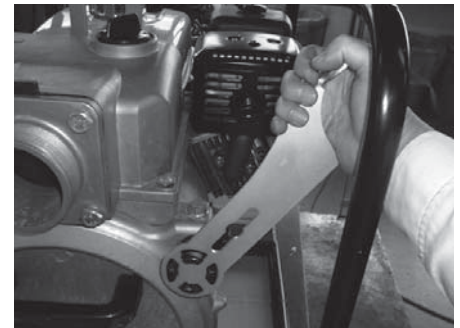

2. Extraiga el impulsor retirando el tapón y retenga una vara contra el impulsor desde el orificio. Entonces, desenrosque una cabeza hexagonal que hay en el centro del impulsor o golpee con martillo el impulsor con la vara.

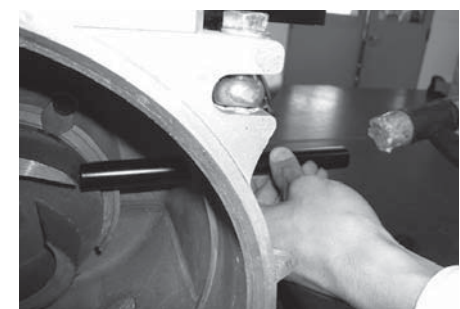
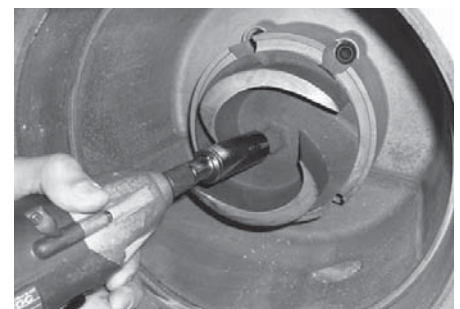

BOMBA DE RESIDUOS *Trabajos pesados*

3. Retire el sello mecánico del impulsor.



4. Retire el sello mecánico del alojamiento de la bomba utilizando dos destornilladores estándar.

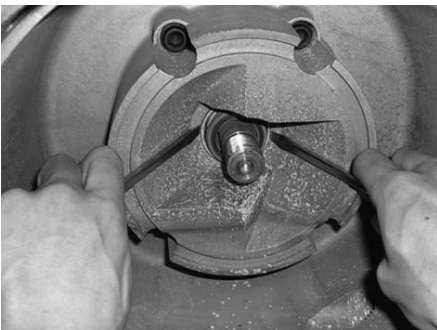

5. Coloque el nuevo sello mecánico en el alojamiento de la bomba manteniendo limpia la superficie del sello. Instale el sello mecánico en el impulsor con las arandelas de ajuste.

PRECAUCIÓN

Mantenga limpia la superficie del sello.

6. Instale el sello mecánico sobre el eje del motor manteniendo limpias las superficies del sello.

7. Vuelva a colocar las arandelas de ajuste del impulsor, la misma cantidad que antes retiró.



8. Install the impeller, and then tighten in a clockwise direction by hand.

PRECAUCIÓN

Be sure seal is set fully and correctly.

9. Tighten the impeller by hitting with a soft hammer in a clockwise direction. The impeller should be fastened tightly so that it cannot be loosened by hand.

10. Install the front cover (with volute casing) in the correct position on the pump casing with O-Ring correctly placed.

11. Correctly install the front cover and evenly tighten the right and left knobs.

PRECAUCIÓN

Ensure all Packings/Gaskets are installed.

BOMBA DE RESIDUOS

ESPAÑOL

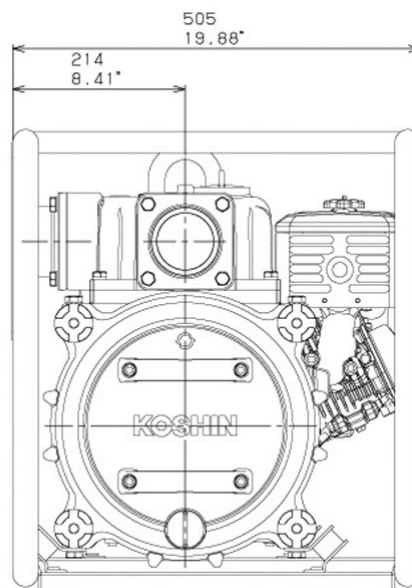
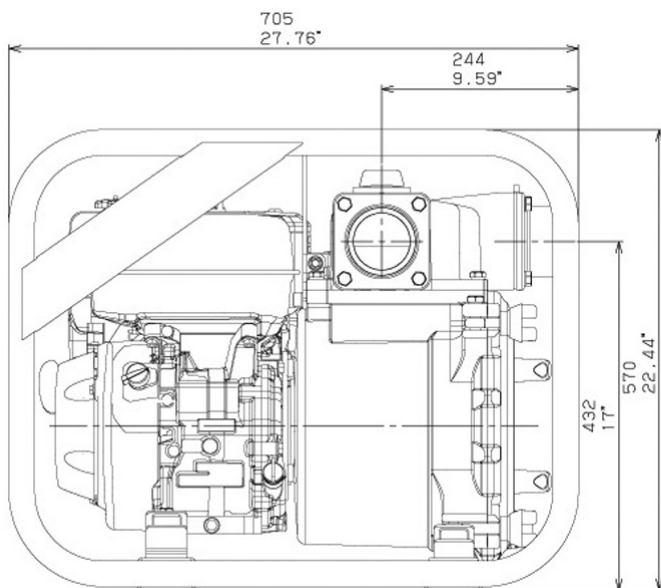

KTH-80S

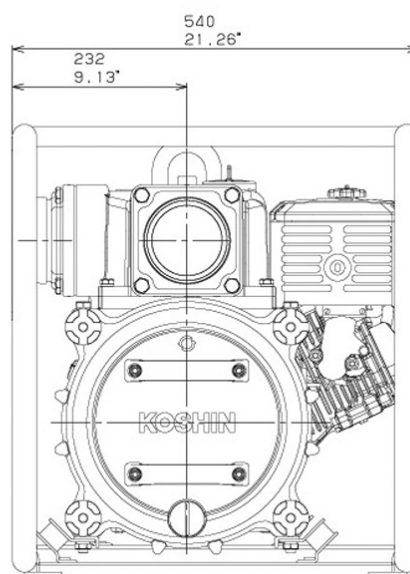
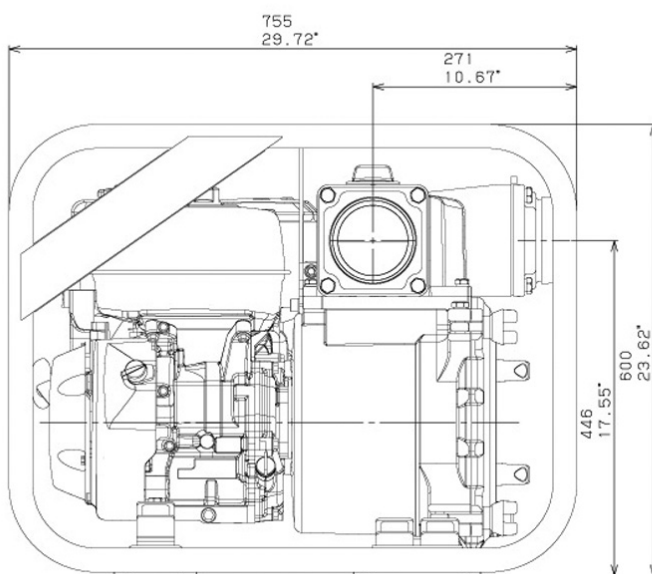

KTH-100S

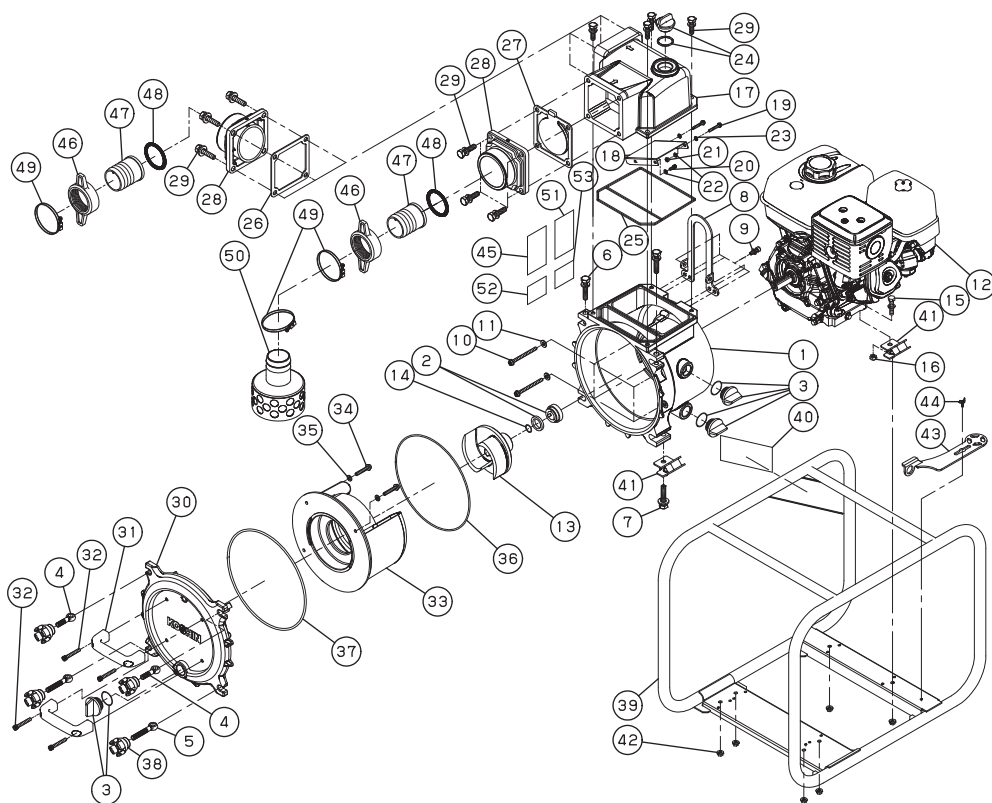

KTH-80S

No.	PARTS CODE	PARTS NAME	QTY	OTHER
1	0121442	Alojamiento de la bomba	1	
2	0115678	Sello mecánico	1	
3	0118079	JUEGO del enchufe de 25 A	3	
4	0121843	Perno S de la cubierta	2	
5	0121844	Perno L de la cubierta	2	
6	743119083	Tornillo de cabeza hueca hexagonal con arandela de resorte de retén M12 x 45	2	
7	743119085	Tornillo de cabeza hueca hexagonal con arandela de resorte de retén M12 x 50	2	
8	0121455	Placa del gancho	1	
9	734614090	Tornillo de tapa de cabeza hueca hexagonal con arandela de resorte M10 x 25	6	
10	0121925	Tornillo de tapa de cabeza hueca hexagonal con brida M10x1,25 x 50	4	
11	0121915	Arandela de aluminio de ø10	4	
12	N/A	Motor GX390UT2	1	
13	0121436	Impulsor	1	
14	0110561	Arandela de ajuste del impulsor T0,3	3	
15	743119067	Tornillo de cabeza hexagonal con arandela de resorte de retén M10 x 40	2	
16	827419010	Tuerca hexagonal M10	1	
17	0121452	Cabeza separada	1	
18	0121832	Deflector	2	
19	734705047	Tornillo de tapa de cabeza hueca hexagonal con brida M6 x 16	2	
20	734505276	Tornillo de tapa de cabeza hueca hexagonal M6 x 8	2	
21	827405006	Tuerca hexagonal M6	4	
22	846205006	Arandela de ø6	2	
23	0121914	Arandela de aluminio de ø6	1	
24	0118450	JUEGO del enchufe de 32A	1	
25	0121450	Empaquetadura de cabeza	1	
26	0110750	Empaquetadura de la brida	2	
27	0121577	Válvula de retención	2	
28	0111365	Brida de succión NPT3	12	BAA
	0116188	Brida de succión G3	1	BAB
29	743119080	Tornillo de cabeza hueca hexagonal con arandela de resorte de retén M12 x 35	8	
30	0121443	Cubierta frontal	1	

No.	PARTS CODE	PARTS NAME	QTY	OTHER
31	0121453	Asa	2	
32	734520070	Tornillo de tapa de cabeza hueca hexagonal M8 x 35	4	
33	0121444	Alojamiento de volutas	1	
34	734705066	Tornillo de tapa de cabeza hueca hexagonal con brida M8 x 25	3	
35	0116493	Arandela de aluminio de ø8	3	
36	0121917	Junta tórica G283 x 3,55	1	
37	0121916	Junta tórica G295 x 5,3	1	
38	0121449	Perilla	4	
39	0128440	Conjunto de la base	1	
40	0121435	Etiqueta, Panel lateral	1	
41	0116172	Almohadilla de goma	4	
42	842319008	Tuerca hexagonal con arandela de cierre de resorte M8	1	
43	0121919	Herramienta múltiple	1	
44	741305153	Perno de aletas M8x15	2	
	0121928	Placa del fabricante KTH-80S-BAA	2	BAA
	0121445	Placa del fabricante KTH-80S-BAB	2	BAB
46	0116189	Acople G3	3	BAB only
47	0110471	Boquilla roscada	1	BAB only
48	0111478	Empaquetadura de acople	1	BAB only
49	940407120	Banda de la manguera	1	BAB only
50	0110979	Boquilla roscada del filtro tipo malla	1	BAB only
51	0114713	Etiqueta, de PRECAUCIÓN	1	BAB only
52	0114718	Etiqueta, marca CE		BAB only
53	0116413	Etiqueta, Ruido EU 106		BAB only
	0114820	Declaración de conformidad de la CE		BAB only

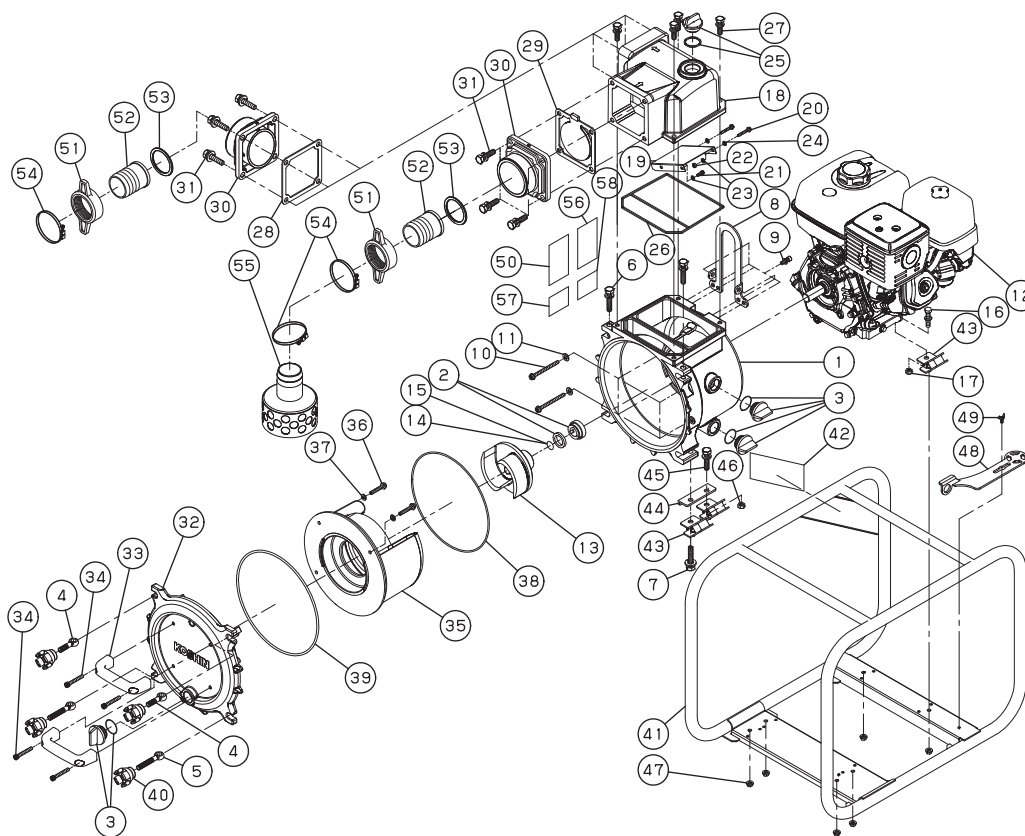

KTH-100S

N.º	CÓDIGO DE PARTE	NOMBRE DE LA PARTE	CANT.	OTROS
1	0121442	Alojamiento de la bomba	1	
2	0115678	Sello mecánico	1	
3	0118079	JUEGO del enchufe de 25 A	3	
4	0121843	Perno S de la cubierta	2	
5	0121844	Perno L de la cubierta	2	
6	743119083	Tornillo de cabeza hueca hexagonal con arandela de resorte de retén M12 x 45	2	
7	743119085	Tornillo de cabeza hueca hexagonal con arandela de resorte de retén M12 x 55	2	
8	0121455	Placa del gancho	1	
9	734614090	Tornillo de tapa de cabeza hueca hexagonal con arandela de resorte M10 x 25	6	
10	0121925	Tornillo de tapa de cabeza hueca hexagonal con brida M10x1,25 x 50	4	
11	0121915	Arandela de aluminio de ø10	4	
12	N/A	Motor GX390UT2	1	
13	0121436	Impulsor	1	
14	0110561	Arandela de ajuste del impulsor T0,3	3	
15	0116405	Arandela de ajuste del impulsor T0,1	3	
16	743119067	Tornillo de cabeza hexagonal con arandela de resorte de retén M10 x 40	2	
17	827419010	Tuerca hexagonal M10	2	
18	0121452	Cabeza separada	1	
19	0121832	Deflector	1	
20	734705047	Tornillo de tapa de cabeza hueca hexagonal con brida M6 x 16	2	
21	734505276	Tornillo de tapa de cabeza hueca hexagonal M6 x 8	2	
22	827405006	Tuerca hexagonal M6	2	
23	846205006	Arandela de ø6	4	
24	0121914	Arandela de aluminio de ø6	2	
25	0118450	JUEGO del enchufe de 32A	1	
26	0121450	Empaquetadura de cabeza	1	
27	743119063	Tornillo de cabeza hexagonal con arandela de resorte de retén M10 x 30	4	
28	0110750	Empaquetadura de la brida	1	
29	0121577	Válvula de retención	1	
30	0111365	Brida de succión NPT4	2	BAA
	0116188	Brida de succión G4	2	BAB

N.º	CÓDIGO DE PARTE	NOMBRE DE LA PARTE	CANT.	OTROS
31	743119080	Tornillo de cabeza hueca hexagonal con arandela de resorte de retén M12 x 35	8	
32	0121443	Cubierta frontal	1	
33	0121453	Asa	2	
34	734520070	Tornillo de tapa de cabeza hueca hexagonal M8 x 35	4	
35	0121444	Alojamiento de volutas	1	
36	734705066	Tornillo de tapa de cabeza hueca hexagonal con brida M8 x 25	3	
37	0116493	Arandela de aluminio de ø8	3	
38	0121917	Junta tórica G283 x 3,55	1	
39	0121916	Junta tórica G295 x 5,3	1	
40	0121449	Perilla	4	
41	0128440	Conjunto de la base	1	
42	0121435	Etiqueta, Panel lateral	1	
43	0116172	Almohadilla de goma	6	
44	0116273	Montura, almohadilla de goma	2	
45	743119076	Tornillo de cabeza hueca hexagonal con arandela de resorte de retén M12 x 25	2	
46	827419012	Tuerca hexagonal M12	2	
47	842319008	Tuerca hexagonal con arandela de cierre de resorte M8	6	
48	0121919	Herramienta múltiple	1	
49	741305153	Perno de aletas M8x15	1	
50	0121928	Placa del fabricante KTH-100S-BAA	1	BAA
	0121446	Placa del fabricante KTH-100S-BAB	1	BAB
51	0116189	Acople G4	2	BAB solamente
52	0110471	Boquilla roscada	2	BAB solamente
53	0111478	Empaquetadura de acople	2	BAB solamente
54	940407120	Banda de la manguera	3	BAB solamente
55	0110979	Boquilla roscada del filtro tipo malla	1	BAB solamente
56	0114713	Etiqueta, de PRECAUCIÓN	1	BAB solamente
57	0114718	Etiquete, marca CE	1	BAB solamente
58	0116413	Etiqueta, Ruido EU 106	1	BAB solamente
	0114820	Declaración de conformidad de la CE	1	BAB solamente

Lire et conserver ces instructions et le manuel d'utilisation du moteur. Les lire attentivement avant d'essayer d'assembler, d'installer, d'utiliser ou d'entretenir le produit décrit.

Se protéger soi-même et protéger les autres en respectant toutes les instructions de sécurité.

Le non-respect de ces instructions peut causer des blessures ou des dommages! Conserver ces instructions pour référence ultérieure.

POMPE À ORDURES *Haute résistance*

Description

Les pompes à ordures fournissent une performance supérieure pour le pompage d'eau sale. Toutes les pompes à ordures ont des joints mécaniques en carbure de silicium, des rotors moulés à forte teneur de chrome et de la fonte ductile à graphite sphéroïde pour obtenir une plus grande longévité. Les moteurs Honda standard avec dispositif d'alerte d'huile sont accouplés avec une pompe légère en aluminium moulé et protégés par une cage de protection. Les volutes sont moulées en fonte à graphite stéroïde, avec des rotors à forte teneur de chrome et des joints mécaniques en carbure de silicium pour augmenter la longévité et réduire la maintenance. Auto-amorçage jusqu'à 8 m (26 pi). Ces pompes sont utilisées pour l'assèchement des chantiers de construction, des sites industriels et civils où l'eau contient des solides pouvant atteindre 38 mm (1 1/2 po). En outre, une poignée sur le couvercle avant fixée horizontalement peut déterminer la direction dans le sens de la longueur.

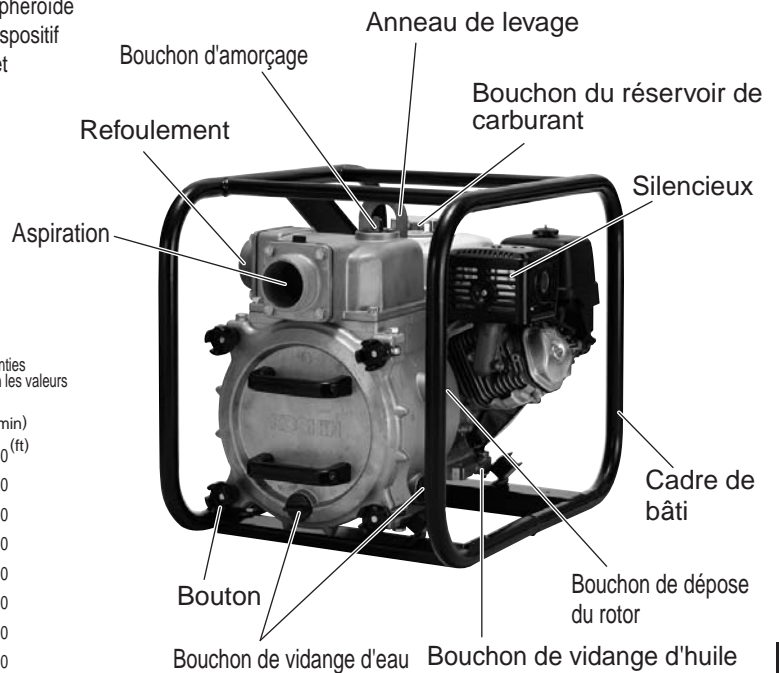

Modèle: KTH-80S

COURBE DES PERFORMANCES

*Les valeurs des performances sont garanties comme étant les valeurs minimum, et non les valeurs augmentées au maximum.

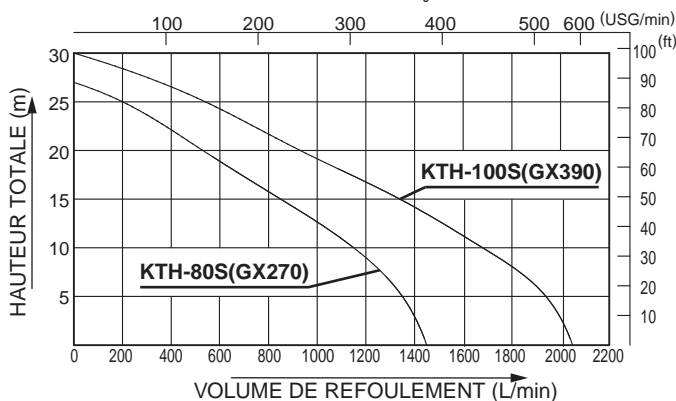

SPÉCIFICATIONS

Modèle		KTH-80S	KTH-100S
POMPE	Diamètre de connexion	80 mm (3 po)	100 mm (4 po)
	Filetage de connexion	Filetage de tuyau parallèle ou NPT	
	Hauteur totale	27 m (89 pi)	30 m (98 pi)
	Volume de refoulement	1 450 L/min (383 USG/min)	2 050 L/min (542 USG/min)
	Hauteur maxi d'aspiration	8 m (26 pi)	
MOTEUR	Type	Moteur à essence 4 temps arbre à came en tête refroidi par air	
	Modèle	Honda GX270	Honda GX390
	Cylindrée	270 cm ³	389 cm ³
	Carburant	Essence sans plomb pour automobile	
	Huile moteur	SAE 10W-30 API SJ ou supérieure pour utilisation générale	
	Contenance du réservoir de carburant	5,3 L	6,1 L
Système de démarrage		Lanceur à rappel	
Accessoire standard		Aucun ou 1 crépine, 2 raccords de tuyau, 3 bandes de tuyau, 1 jeu d'outils de moteur	
Poids net		66 kg (146 lbs)	82 kg (181 lbs)
Puissance sonore garantie		LWA 105 dB	LWA 106 dB

POMPE À ORDURES

This manual is prepared for your safety when operating pump. Please read carefully and comprehend fully before use. (Wrong usage could cause injury or death.) Please keep this manual handy for future reference.

Unpacking

Upon receiving the pump it should be inspected for any damage and/or missing parts. If there is any damage, file a claim with the carrier who delivered the pump. Ensure the Pump Model is correct and keep all operating manuals with the pump for reference.

CAUTION

Do not operate unit if there is any damage due to shipping, handling, or use. Damage may cause injury or property damage.

Safety Precautions

Read these "Safety Precautions" before operation.

This manual contains information that is very important to know and understand. This information is provided for the SAFETY and to PREVENT EQUIPMENT PROBLEMS.

To help recognize this information, observe the following symbols:

DANGER

















Indicates an imminently hazardous situation which, if not avoided, will result in death or serious injury.









WARNIG

Indicates a potentially hazardous situation which, if not avoided, could result in death or serious injury.

CAUTION

Indicates a potentially hazardous situation which, if not avoided, may result in minor or moderate injury, or property damage.

 DANGER
 <p>Avoid open flames or spark when refueling or maintaining the pump or engine.</p>  <p>Gasoline and vapors are highly flammable!</p>
 <p>Do not operate Engine pump inside a room or confined area without proper ventilation.</p>  <p>Exhaust gases are dangerous. There is danger of gas poisoning.</p> 
 <p>Do not use pump on slope. Fuel leakage at fuel tank or carburetor may cause fire.</p> 
 <p>Keep area around the engine muffler free of debris—muffler can be very hot. It may cause fire or breakage.</p> 
 <p>Read carefully and understand fully before use.</p> 
 <p>Keep children away from pump when in operation.</p> 
 <p>Do not overhaul, service or repair, except by a qualified person who is trained to do so.</p> 

 WARNIG
 <p>This pump is designed to pump water. Not to be used for drinking water, chemicals, or flammable liquids.</p> 
 <p>Water temperature range is 35°F/105°F (2°C/41°C). Damage may result if not followed.</p> 
 <p>Do not run pump dry. This will cause premature wear and/or failure.</p> 
 <p>Please use proper suction hose and connectors at suction side of pump.</p> 

CAUTION

Do not operate the pump without proper training. Know how to stop the pump quickly and understand the operation of all of the controls. Attach discharge hose before operating pump. Do not restrict or obstruct discharge hose.

Personal Safety

Wear eye protection at all times when operating or maintaining pumps. Keep area of operation clean, uncluttered and properly lighted; replace all unused tools and equipment. Must keep visitors at a safe distance from the area of operation.

POMPE À ORDURES *Haute résistance*

L'essence et ses vapeurs sont très inflammables.

- Utiliser uniquement de l'essence.
- Utiliser uniquement un bidon approuvé pour stocker l'essence.
- Garder l'essence à l'abri de la chaleur, des étincelles et des flammes.
- Un extincteur doit être présent lors du travail avec de l'essence.
- Il faut une ventilation adéquate pendant la manutention de liquides inflammables.
- Il est interdit de fumer.

ATTENTION

Avant de faire fonctionner la pompe, vérifier que le tuyau de refoulement est sécurisé. Un tuyau de refoulement desserré peut glisser et causer des dommages ou des blessures. Ne pas serrer excessivement les raccords filetés. Vérifier les tuyaux et tous les branchements avant l'utilisation. Inspecter la pompe et ses accessoires avant chaque utilisation. Évacuer l'eau de la pompe avant tout travail d'entretien. Une mauvaise utilisation peut causer des blessures ou un décès. Conserver ce manuel pour référence ultérieure.

AVANT L'UTILISATION

1. Vérifier que tous les accessoires sont présents.

La liste des accessoires fournis est imprimée dans le manuel de la pompe.

2. Le moteur à 4 temps a besoin d'huile moteur.

Consulter la vérification du niveau d'huile à la figure 4.

Verser l'huile moteur dans l'orifice d'huile situé au bas du moteur, comme indiqué sur l'illustration.

Changer l'huile toutes les 8 heures pendant les premières 20 heures de service, et toutes les 50 heures ensuite. Huile utilisée: SAE#30 (printemps et été) SAE#20 (automne et hiver) SAE10W-30 (régions froides, au-dessous de 10°C)

Il faut toujours vérifier le niveau d'huile moteur avant chaque utilisation. Utiliser uniquement de l'essence ordinaire sans plomb.

ATTENTION

Pas d'huile ou un niveau trop bas endommage le moteur prématurément. La garantie ne couvre pas les cas de bas niveau d'huile.

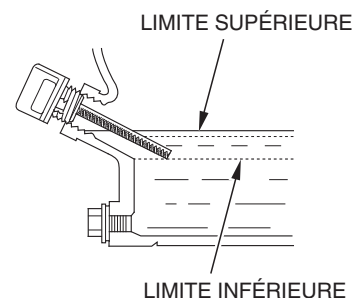
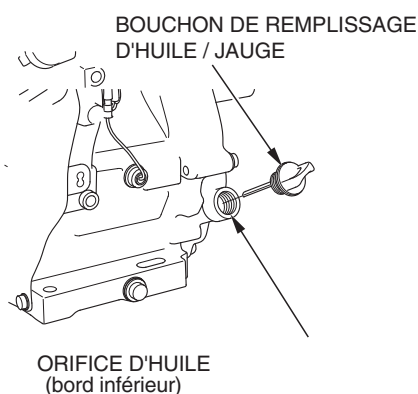

3. Installer les raccords dans l'ordre suivant : ① → ② → ③

Consulter l'installation des raccords à la figure 5.

Si cet ensemble de raccord n'est pas installé correctement comme indiqué à la figure 5, il y aura une fuite et la pompe ne pourra pas s'amorcer.

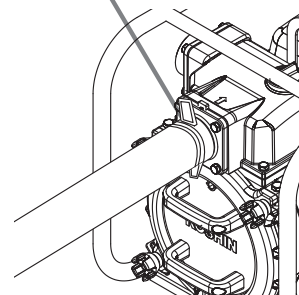
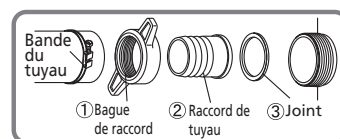

POMPE À ORDURES

4. Ne pas utiliser un tuyau d'aspiration de diamètre plus petit.

L'utilisation d'un tuyau d'aspiration de diamètre plus petit peut causer la cavitation de la pompe. La cavitation entraînera une défaillance du joint mécanique.

5. Vérifier que le tuyau d'aspiration est branché correctement.

Pour éviter les fuites d'air et un amorçage lent, vérifier que le tuyau d'aspiration est branché correctement.

ATTENTION

Si cette opération n'est pas effectuée, la pompe ne pourra pas s'amorcer.

6. Vérifier que la pompe est bien complètement remplie d'eau.

ATTENTION

Le fonctionnement à sec peut causer des dommages graves ou une défaillance du joint mécanique.

UTILISATION

1. Avant le démarrage, vérifier que le carter de la pompe est complètement rempli de liquide (amorcé). Si la pompe n'est pas correctement amorcée, elle sera endommagée.

2. Vérifier que la crépine à l'extrémité du tuyau d'aspiration est complètement immergée dans l'eau. S'il y a de la boue ou du sable au fond de l'eau, suspendre le tuyau pour éviter l'aspiration de débris.

3. Ne pas tordre le tuyau ni bloquer ou empêcher le passage du liquide dans le tuyau de refoulement.

ATTENTION

Attention aux coups de bélier. Veiller à ce qu'aucun véhicule ne roule sur le tuyau de refoulement. Ne pas fermer brusquement la vanne de refoulement car ceci pourrait causer un coup de bélier. La pompe risquerait alors d'être fortement endommagée.

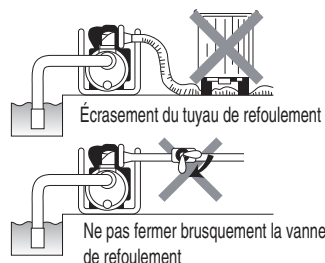

Consulter les instructions pour le moteur et les remarques dans le manuel d'utilisation du moteur fourni.

APRÈS L'UTILISATION

Après l'utilisation, retirer le bouchon de vidange situé au bas et verser de l'eau par les orifices d'aspiration/refoulement, afin que le sable restant soit expulsé de la pompe.

Si la pompe est utilisée pour transférer de l'eau boueuse pendant une longue période, un grand volume de sable s'accumulera dans le carter de la pompe, et il sera alors difficile de retirer le couvercle avant. Il faut donc nettoyer périodiquement l'intérieur de la pompe.

ATTENTION

L'eau se trouvant à l'intérieur de la pompe peut geler à moins de 0°C en hiver et peut endommager la pompe. Après avoir utilisé la pompe, évacuer l'eau par le bouchon de vidange avant de ranger la pompe.

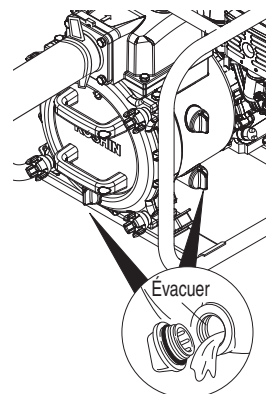

Rangement à long terme

Évacuer complètement le carburant du réservoir de carburant et du carburateur. L'essence laissée plus de 30 jours dans le réservoir peut causer une défaillance du moteur. * Consulter le manuel d'utilisation du moteur.

ATTENTION

Ne pas fumer ou exposer à une flamme vive ou à des étincelles, car l'essence est très inflammable. L'essence ne doit pas rester dans le réservoir pour le rangement à long terme. De la vieille essence pourra par la suite causer une défaillance du moteur.

POMPE À ORDURES *Haute résistance*

Troubleshooting

SYMPTOM	POSSIBLE CAUSE(S)	CORRECTIVE ACTION
Cannot pull or hard to pull recoil starter	<ol style="list-style-type: none"> 1. Old fuel 2. Rusting inside engine 3. Burn out of engine 4. Blocked impeller 5. Debris at impeller 	<ol style="list-style-type: none"> 1. Replace fuel. If there is no improvement, repair engine 2. Refer to Engine Operation Manual. (Repair) 3. Refer to Engine Operation Manual. (Repair) 4. Dismantle & clean the impeller ⇒ SOLUTION ① 5. Dismantle & clean the impeller
Low delivery volume	<ol style="list-style-type: none"> 1. Air leakage from suction side 2. Output power down from engine 3. Damage of mechanical seal 4. Suction lift is high 5. Suction pipe is too long or too small in diameter 6. Water leaking from delivery hose or pipe 7. Debris at impeller 8. Worn or broken impeller 	<ol style="list-style-type: none"> 1. Check hose at suction side ⇒ SOLUTION ② 2. Check and repair engine 3. Replace mechanical seal (Repair) 4. Decrease suction lift 5. Shorten suction pipe or enlarge repair to proper diameter 6. Check and stop leakage of water 7. Dismantle & clean the impeller ⇒ SOLUTION ① 8. Replace the impeller (Repair)
Pump does not prime water	<ol style="list-style-type: none"> 1. Air leaking in from suction side 2. Insufficient priming water Inside pump casing 3. Drain plug is not tightened 4. Engine speed/rpm is too low 5. Damage of mechanical seal (NOTE) 6. Wrong suction hose used 	<ol style="list-style-type: none"> 1. Check hose and connections at suction side ⇒ SOLUTION ② 2. Fill pump with water for priming Refer to BEFORE USE - "5 Fill pump with water before use" 3. Tighten drain plug firmly. Please refer to "ATTENTION AFTER USE" 4. Refer to Engine Operation Manual 5. Replace mechanical seal (Repair) 6. Use suction hose correctly
Engine does not start	<ol style="list-style-type: none"> 1. Carburetor is choked/blocked 2. Spark Plug is wet 3. Air cleaner dirty 4. Too much engine oil (4-cycle engine) 5. Insufficient engine oil (4-stroke engine) 6. After checking above points, still engine does not start 	<ol style="list-style-type: none"> 1. Repair ⇒ SOLUTION ③ 2. Check & repair the plug 3. Clean air cleaner. (Refer to Engine Operation Manual) 4. Adjust engine oil to suitable level 5. Function of oil alert (oil sensor) is working. (This function protects engine. If volume of engine oil is not a suitable level, engine does not start) 6. Possibility of damage, inner parts of engine (Repair)
Oil leakage from muffler or air cleaner	<ol style="list-style-type: none"> 1. Tipping of engine 	<ol style="list-style-type: none"> 1. Clean engine (Air Cleaner, Carburetor, Muffler, Spark plug, etc.)

POMPE À ORDURES

SOLUTION ①

Déposer le couvercle avant et enlever les débris du rotor.

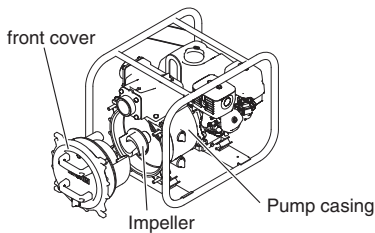

SOLUTION ②

Vérifier le tuyau d'aspiration. S'il n'y a pas d'aspiration ou si le refoulement est faible, la cause est généralement une fuite d'air sur le côté aspiration. Dans ce cas:

1. Retirer le tuyau d'aspiration.

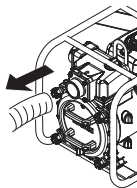

2. Lancer le moteur avec de l'eau dans la pompe.

3. Boucher le trou d'aspiration avec la paume de la main et attendre 30 secondes. Si de l'aspiration est sentie sur la paume, la pompe fonctionne correctement, mais le raccord du tuyau doit être corrigé. Test d'aspiration

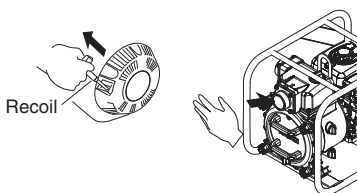

4. Vérifier que le joint de caoutchouc ou garniture est bien installé, et qu'il n'y a pas de trou dans le tuyau d'aspiration.

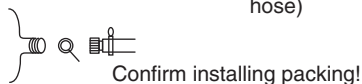
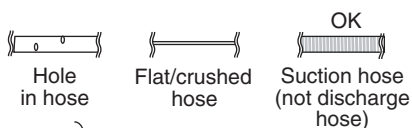

SOLUTION ③

Vérifier que la bougie est propre et sans débris. Si ce n'est pas le cas, utiliser un chiffon propre pour enlever les taches et les saletés. Vérifier l'écartement des électrodes de la bougie. L'écartement doit être entre 0,6 et 0,7 mm ou 0,024 et 0,028 po. Régler l'écartement dans cette plage.

Il pourra être nécessaire de remplacer la bougie si le moteur ne démarre toujours pas après avoir nettoyé la bougie et réglé l'écartement des électrodes.

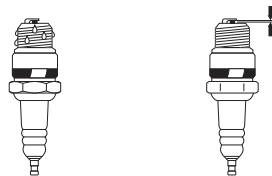

ATTENTION

Il existe de nombreux différents types de bougies. Consulter le manuel d'utilisation du moteur pour choisir le type de bougie correct.

REMARQUE:

Une fuite entre le carter de la pompe et le moteur est habituellement causée par un joint mécanique endommagé. Consulter un centre de réparation local.

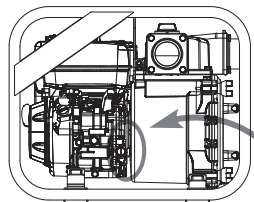

ATTENTION

Pour obtenir de l'assistance pour les vérifications et les réparations, s'adresser au service après-vente du magasin le plus proche.

ENTRETIEN

Remplacement du joint mécanique

1. Tourner le bouton dans le sens inverse des aiguilles d'une montre et déposer le bouton. Tirer la poignée vers soi; le couvercle avant et le carter de volute pourront alors tous deux être déposés.

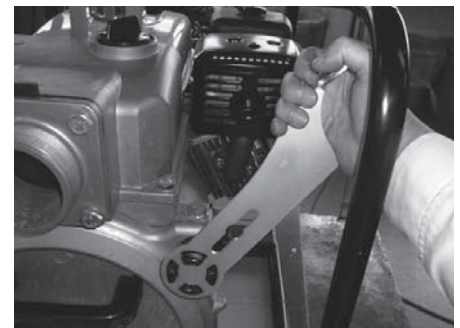

2. Retirer le bouchon de dépôt du rotor et tenir une tige contre le rotor depuis le trou. Ensuite, dévisser une tête hexagonale au centre du rotor ou marteler le rotor par l'intermédiaire de la tige.

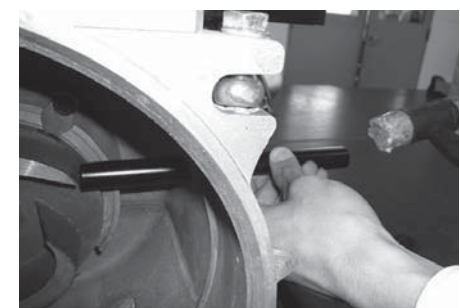
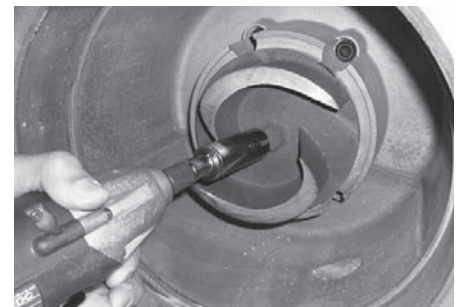

POMPE À ORDURES *Haute résistance*

3. Retirer le joint mécanique du rotor.



4. Déposer le joint mécanique du carter de pompe en utilisant deux tournevis standard.

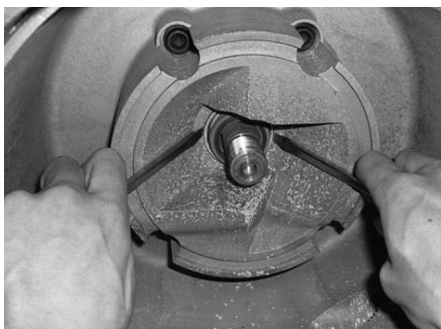

5. Poser le joint mécanique neuf dans le carter de pompe en prenant soin de maintenir la surface du joint propre. Installer le joint mécanique dans le rotor avec les rondelles de réglage.

ATTENTION

Maintenir propre la face du joint.

6. Installer le joint mécanique sur l'arbre du moteur en gardant propre les faces du joint.

7. Remettre en place les rondelles de réglage du rotor, le même nombre qu'à la dépose.

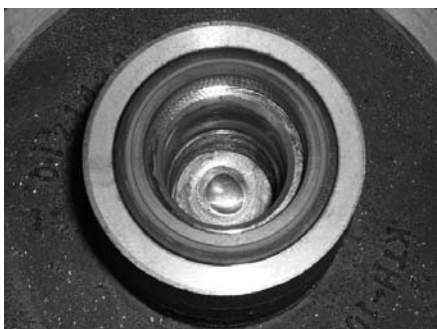

8. Installer le rotor et serrer à la main dans le sens des aiguilles d'une montre.

ATTENTION

Veiller à ce que le joint soit mis complètement et correctement en place.

9. Serrer le rotor en le percutant avec un maillet à panne douce dans le sens des aiguilles d'une montre. Le rotor doit être serré bien fermement afin qu'il ne puisse pas être desserré avec la main.

10. Installer le couvercle avant (avec le carter de volute) à la position correcte sur le carter de pompe avec le joint torique correctement placé.

11. Installer correctement le couvercle avant et serrer uniformément les boutons droit et gauche.

ATTENTION

Vérifier que toutes les garnitures et joints sont bien installés.

POMPE À ORDURES

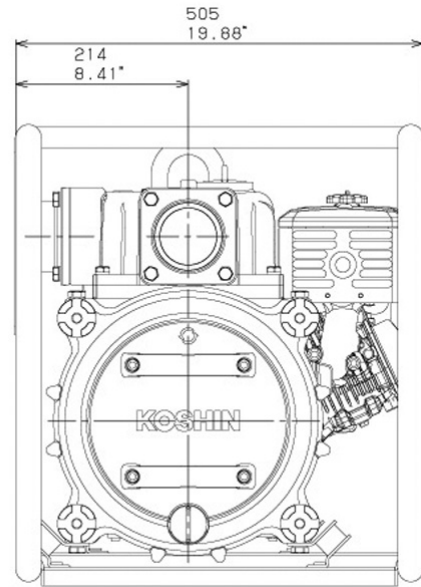
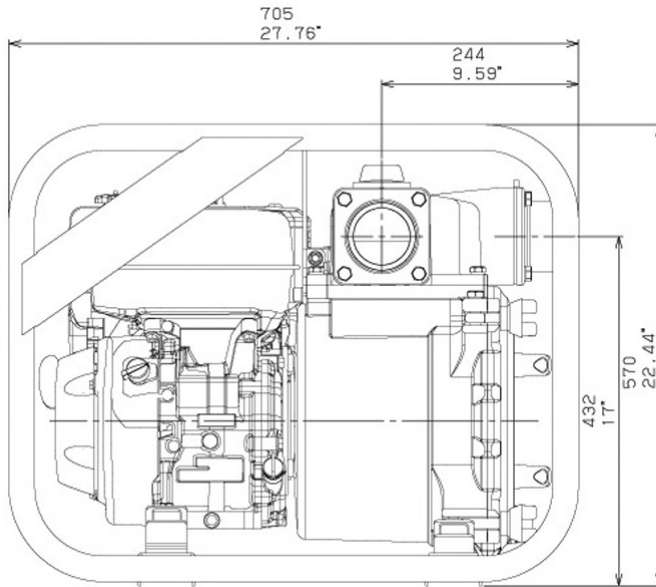

KTH-80S

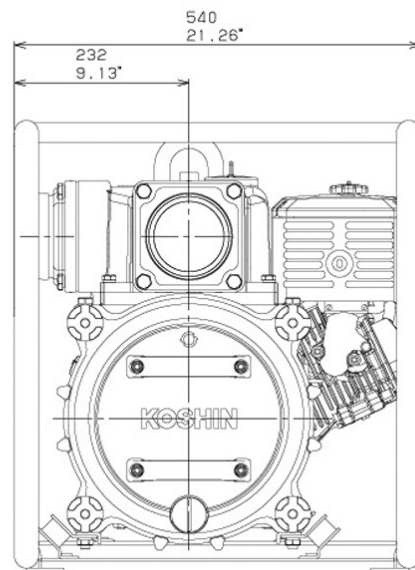
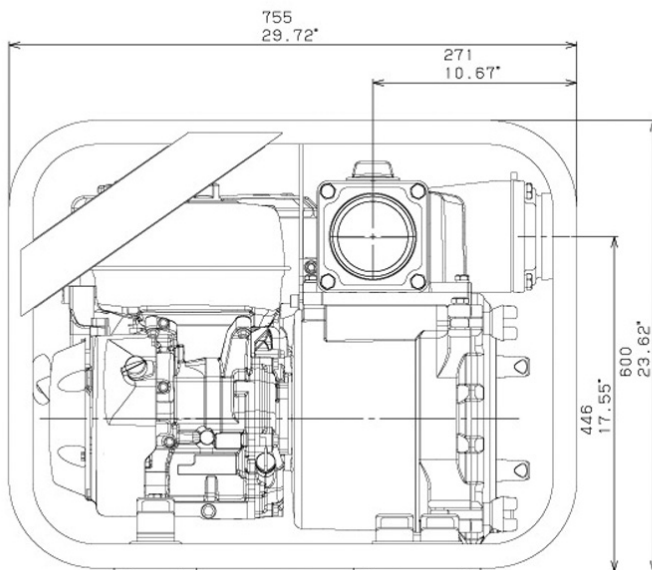

KTH-100S

F
R
A
N
Ç
A
I
S

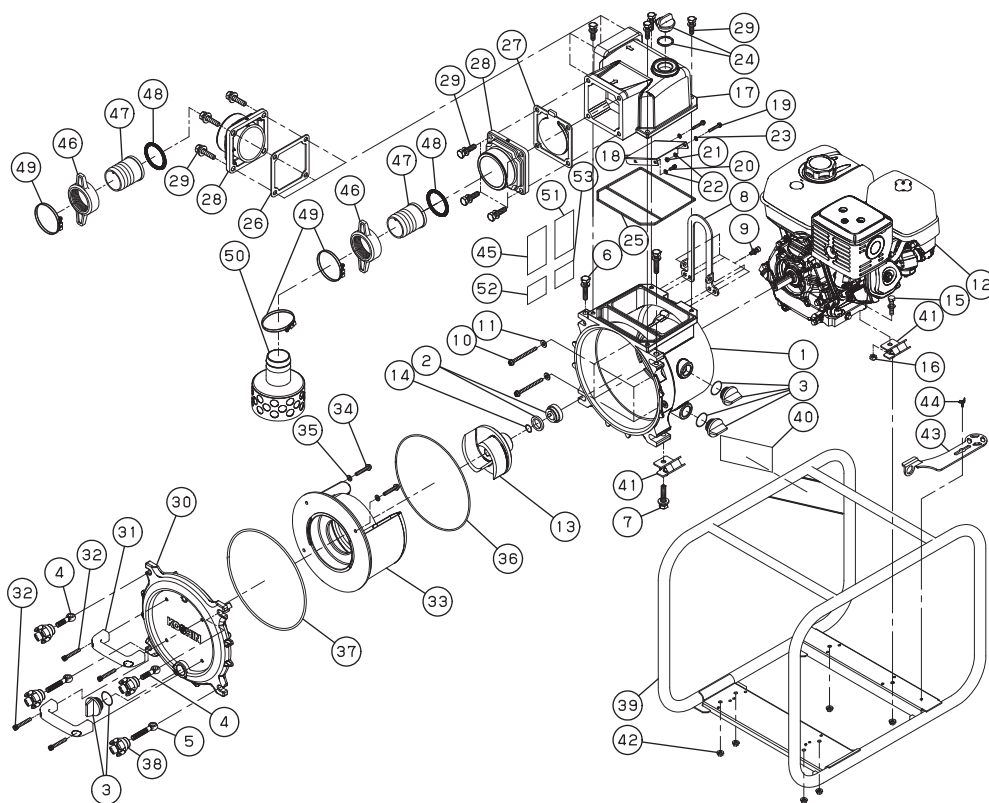

KTH-80S

N°	CODE DES PIÈCES	NOM DES PIÈCES	QTÉ	AUTRES
1	0121442	Cartier de pompe	1	
2	0115678	Joint mécanique	1	
3	0118079	JEU de bouchon 25A	3	
4	0121843	Boulon de couvercle – petit	2	
5	0121844	Boulon de couvercle – grand	2	
6	743119083	Vis à tête hexagonale avec rondelle élastique captive M12 x 45	2	
7	743119085	Vis à tête hexagonale avec rondelle élastique captive M12 x 55	2	
8	0121455	Plaque à crochet	1	
9	734614090	Vis à tête cylindrique à six pans creux avec rondelle élastique M10 x 25	6	
10	0121925	Vis à tête cylindrique à six pans creux avec bride M10 x 1.25 x 50	4	
11	0121915	Rondelle en aluminium x10	4	
12	N/A	Moteur GX390UT2	1	
13	0121436	Rotor	1	
14	0110561	Rondelle de réglage de rotor T0.3	3	
15	743119067	Vis à tête hexagonale avec rondelle élastique captive M10 x 40	2	
16	827419010	Écrou hexagonal M10	1	
17	0121452	Cartier séparé	1	
18	0121832	Cloison	2	
19	734705047	Vis à tête cylindrique à six pans creux avec bride M6 x 16	2	
20	734505276	Vis à tête cylindrique à six pans creux M6 x 8	2	
21	827405006	Écrou hexagonal M6	4	
22	846205006	Rondelle x6	2	
23	0121914	Rondelle en aluminium x6	1	
24	0118450	JEU de bouchon 32A	1	
25	0121450	Joint de carter	1	
26	0110750	Garniture de bride	2	
27	0121577	Clapet antiretour	2	
28	0111365	Bride d'aspiration NPT4	12	BAA
	0116188	Bride d'aspiration G4	1	BAB
29	743119080	Vis à tête hexagonale avec rondelle élastique captive M12 x 35	8	
30	0121443	Couvercle avant	1	

N°	CODE DES PIÈCES	NOM DES PIÈCES	QTÉ	AUTRES
31	0121453	Poignée	2	
32	734520070	Vis à tête cylindrique à six pans creux M8 x 35	4	
33	0121444	Cartier de volute	1	
34	734705066	Vis à tête cylindrique à six pans creux avec bride M8 x 25	3	
35	0116493	Rondelle en aluminium x8	3	
36	0121917	Joint torique G283 x 3.55	1	
37	0121916	Joint torique G295 x 5.3	1	
38	0121449	Bouton	4	
39	0128440	Bâti de support	1	
40	0121435	Étiquette, panneau latéral	1	
41	0116172	Butée de caoutchouc	4	
42	842319008	Écrou hexagonal avec rondelle de blocage élastique M8	1	
43	0121919	Outil multi-usages	1	
44	741305153	Vis papillon M8x15	2	
45	0121928	Plaque signalétique KTH-100S-BAA	2	BAA
	0121445	Plaque signalétique KTH-100S-BAB	2	BAB
46	0116189	Bague de raccord G4	3	BAB only
47	0110471	Raccord	1	BAB only
48	0111478	Joint	1	BAB only
49	940407120	Bande de tuyau	1	BAB only
50	0110979	Raccord de crépine	1	BAB only
51	0114713	Étiquette, ATTENTION	1	BAB only
52	0114718	Étiquette, marque CE		BAB only
53	0116413	Étiquette, bruit UE 106		BAB only
	0114820	Déclaration de conformité CE		BAB only

FRANÇAIS

POMPE À ORDURES

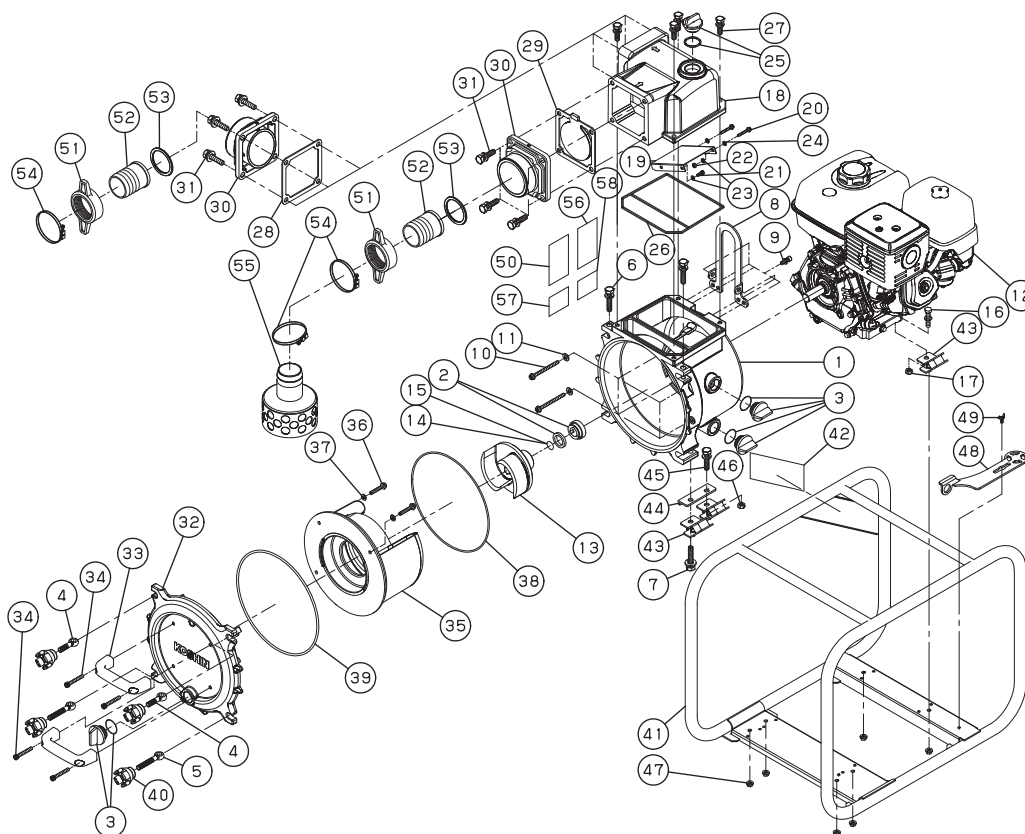

KTH-100S

N°	CODE DES PIÈCES	NOM DES PIÈCES	QTÉ.	AUTRES
1	0121442	Cartier de pompe	1	
2	0115678	Joint mécanique	1	
3	0118079	JEU de bouchon 25A	3	
4	0121843	Boulon de couvercle – petit	2	
5	0121844	Boulon de couvercle – grand	2	
6	743119083	Vis à tête hexagonale avec rondelle élastique captive M12 x 45	2	
7	743119085	Vis à tête hexagonale avec rondelle élastique captive M12 x 55	2	
8	0121455	Plaque à crochet	1	
9	734614090	Vis à tête cylindrique à six pans creux avec rondelle élastique M10 x 25	6	
10	0121925	Vis à tête cylindrique à six pans creux avec bride M10 x 1.25 x 50	4	
11	0121915	Rondelle en aluminium x10	4	
12	N/A	Moteur GX390UT2	1	
13	0121436	Rotor	1	
14	0110561	Rondelle de réglage de rotor T0.3	3	
15	0116405	Rondelle de réglage de rotor T0.1	3	
16	743119067	Vis à tête hexagonale avec rondelle élastique captive M10 x 40	2	
17	827419010	Écrou hexagonal M10	2	
18	0121452	Cartier séparé	1	
19	0121832	Cloison	1	
20	734705047	Vis à tête cylindrique à six pans creux avec bride M6 x 16	2	
21	734505276	Vis à tête cylindrique à six pans creux M6 x 8	2	
22	827405006	Écrou hexagonal M6	2	
23	846205006	Rondelle x6	4	
24	0121914	Rondelle en aluminium x6	2	
25	0118450	JEU de bouchon 32A	1	
26	0121450	Joint de cartier	1	
27	743119063	Vis à tête hexagonale avec rondelle élastique captive M10 x 30	4	
28	0110750	Garniture de bride	1	
29	0121577	Clapet antiretour	1	
30	0111365	Bride d'aspiration NPT4	2	BAA
	0116188	Bride d'aspiration G4	2	BAB

N°	CÓDIGO DE PARTE	NOM DES PIÈCES	QTÉ.	AUTRES
31	743119080	Vis à tête hexagonale avec rondelle élastique captive M12 x 35	8	
32	0121443	Couvercle avant	1	
33	0121453	Poignée	2	
34	734520070	Vis à tête cylindrique à six pans creux M8 x 35	4	
35	0121444	Cartier de volute	1	
36	734705066	Vis à tête cylindrique à six pans creux avec bride M8 x 25	3	
37	0116493	Rondelle en aluminium x8	3	
38	0121917	Joint torique G283 x 3.55	1	
39	0121916	Joint torique G295 x 5.3	1	
40	0121449	Bouton	4	
41	0128440	Bâti de support	1	
42	0121435	Étiquette, panneau latéral	1	
43	0116172	Butée de caoutchouc	6	
44	0116273	Fixation, butée de caoutchouc	2	
45	743119076	Vis à tête hexagonale avec rondelle élastique captive M12 x 25	2	
46	827419012	Écrou hexagonal M12	2	
47	842319008	Écrou hexagonal avec rondelle de blocage élastique M8	6	
48	0121919	Outil multi-usages	1	
49	741305153	Vis papillon M8x15	1	
50	0121928	Plaque signalétique KTH-100S-BAA	1	BAA
	0121445	Plaque signalétique KTH-100S-BAB	1	BAB
51	0116189	Bague de raccord G4	2	BAB uniquement
52	0110471	Raccord	2	BAB uniquement
53	0111478	Joint	2	BAB uniquement
54	940407120	Bande de tuyau	3	BAB uniquement
55	0110979	Raccord de crépine	1	BAB uniquement
56	0114713	Étiquette, ATTENTION	1	BAB uniquement
57	0114718	Étiquette, marque CE	1	BAB uniquement
58	0116413	Étiquette, bruit UE 106	1	BAB uniquement
	0114820	Déclaration de conformité CE	1	BAB uniquement

KOSHIN

Thank you for choosing KOSHIN

If you need service, please contact us through our global site gateway.

GLOBAL SITE GATEWAY

WWW.KOSHINPUMP.COM

Engineering by **KOSHIN LTD.**

12 Kami-Hachinotsubo Kotari, Nagaokakyo City, Kyoto 617-8511 JAPAN

TEL.+81-75-954-6111 FAX.+81-75-954-6119

e-mail : info@koshin-ltd.co.jp