

# KOSHIN

## CLEAR WATER PUMP

### OWNER'S MANUAL

SEV-25S, SEV-50S, SEV-80S

1. SAFETY .....	3
2. COMPONENT IDENTIFICATION .....	8
3. CONTROL SYSTEM .....	10
4. PRE-OPERATION INSPECTION .....	13
5. OPERATION .....	18
6. STARTING THE ENGINE .....	22
7. STOPPING THE ENGINE .....	25
8. MAINTENANCE .....	27
9. STORAGE .....	32
10. TROUBLESHOOTING .....	34
11. SPECIFICATION .....	36

## KOSHIN LTD.

[www.koshinamerica.com/](http://www.koshinamerica.com/)

Toll Free: 1-800-634-4092

E-Mail: [CustomerService@koshinamerica.com](mailto:CustomerService@koshinamerica.com)

## **PREFACE**

Thank you for choosing a water pump of our company.

Please keep the owner's manual for reference.

This manual should be considered a permanent part of the water pump and should remain with the water pump if it is resold.

The manual instructs the user how to operate the water pump including the models of SEV-25S, SEV-50S, and SEV-80S, and be sure to read it carefully first before operation to get the best results. If a problem should arise or if you have any questions about the pump, consult an authorized dealer of our company.

All information and diagrams of this manual are provided in accordance with the newest products at the publishing time. If revision or any other change is made in respect of the information described in this manual, making it a little different from the product's actual status, our company will explain it. Our company reserves the right to make changes at any time without notice and without incurring any obligation. No part of this publication may be reproduced without written permission of our company.

# 1. SAFETY

Our company's water pump is designed to give safe and reliable service if operated according to instructions. Read and understand the Owner's Manual before operating the water pump. Failure to do so could result in personal injury or equipment damage.

## Safety Messages

Your safety and the safety of others are very important. We have provided important safety messages in this manual and on water pump and engine. Please read these messages carefully.

Safety label - on the water pump and engine.

A safety message - alerts you to potential hazards that could hurt you or others. Each safety message is preceded by a safety alert symbol  and one of three words: WARNING, CAUTION, or NOTICE. These mean:



You CAN be KILLED or SERIOUSLY HURT if you don't follow instructions.



You CAN be HURT if you don't follow instructions.



Your water pump or other property could be damaged if you don't follow instructions.

## 1) Safety Instruction

Clean water pump and high pressure pump are only designed for pumping clean water.

Pump only water that is not intended for human consumption. Pumping flammable liquids, such as gasoline or fuel oils, can result in a fire or explosion, causing serious injury. Pumping sea water, beverages, acids, chemical solutions, or any other liquid that promotes corrosion can damage the pump.

To prevent fire hazards and to provide adequate ventilation, keep the pump at least 1 meter away from each of the building walls and other equipment during operation. Do not place flammable objects close to the pump and do not fill the fuel tank with gasoline before long distance transportation.

The muffler becomes very hot during operation and remains hot for a while after stopping the engine. Be careful not to touch the muffler while it is hot. Let the engine cool before storing the water pump indoors.

Gasoline is highly flammable and explosive. Don't smoke in the refueling and fuel storage area. Avoid open flames or spark when refueling or maintaining the pump or engine.

If you leave the pump for any reason, always turn the engine off.

Do not open plugs or hoses if heat or pressure exists within the pump.

Place the pump on a firm, level surface. If the pump is tilted or overturned, fuel spillage may result.

Refuel in a well-ventilated area with the engine stopped, and in places for refueling or storing gasoline. If spilling occurs, immediately clean it. After refueling, cover the fuel tank well and screw it down.

Exhaust contains poisonous carbon monoxide gas that can build up to dangerous levels in closed areas. Breathing carbon monoxide can cause unconsciousness or death.

Don't screw off the plug while the engine is running to avoid damaging the equipment and hurting the persons.

Children and pets must be kept away from the area of operation due to a possibility of burns from the hot engine components.

The machine is forbidden to be operated in a potentially explosive atmosphere.

## 2) Safety Label

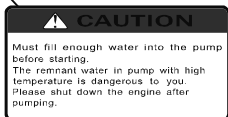
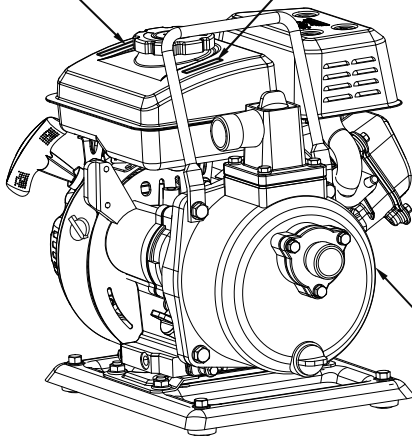

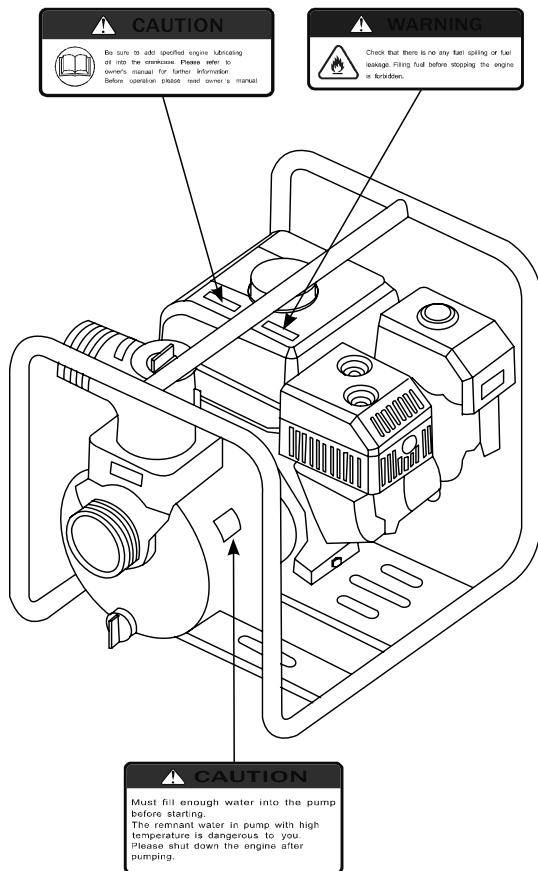

## 2. COMPONENT IDENTIFICATION

### CLEAN WATER PUMP

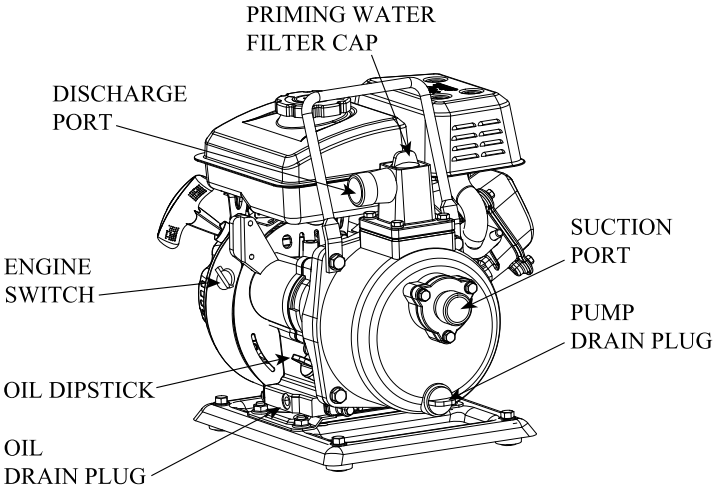
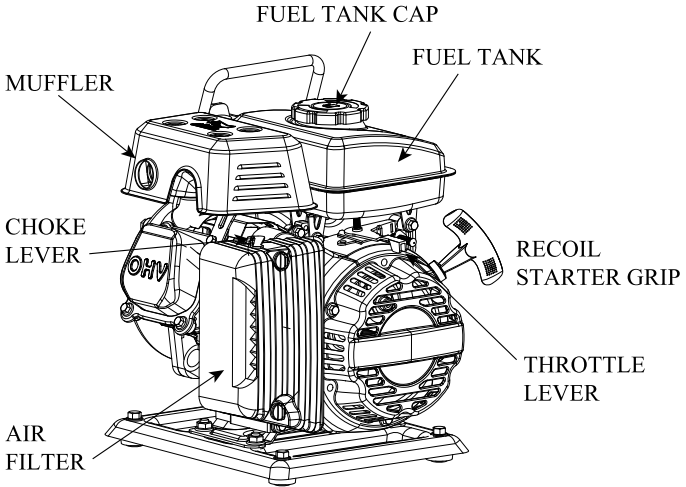



# CLEAN WATER PUMP

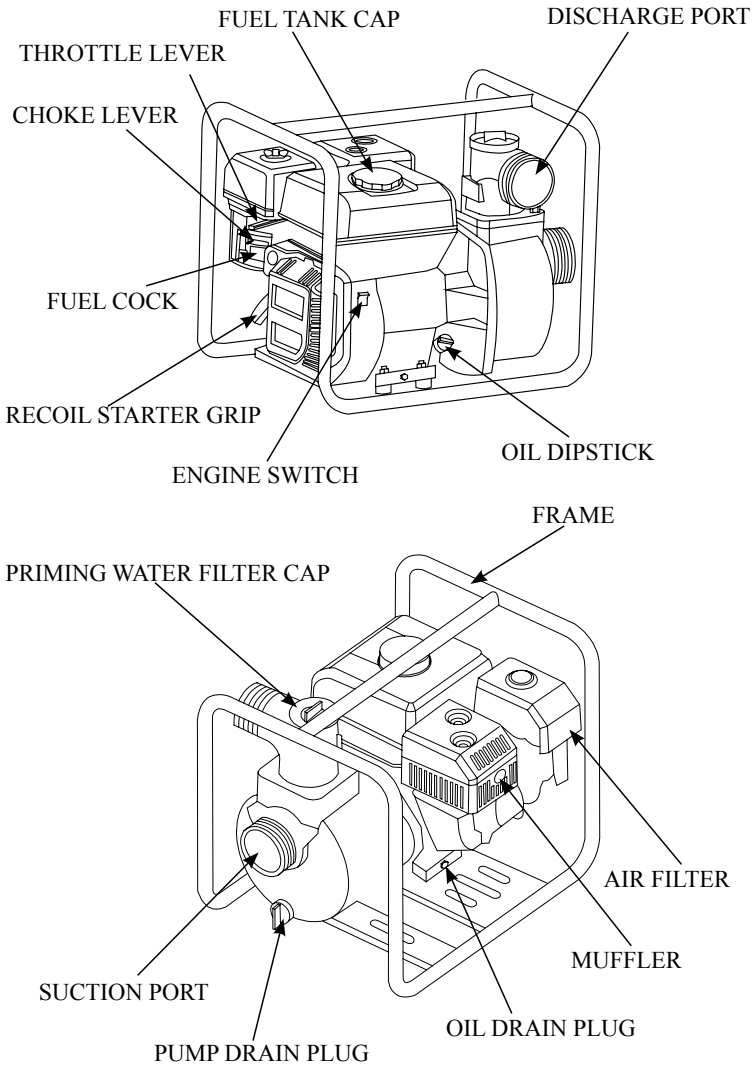

### 3. CONTROL SYSTEM

Before operating our company's water pump, carefully read and understand the owner's manual and be familiar with each control function. Know how to operate and how to do in a urgency condition.

#### 1) Fuel Lever (SEV-50S, -80S only)

The fuel lever is used for fuel flowing from the fuel tank to carburetor.

Set the fuel lever to the "OPEN" position.

When not operating the engine, set the fuel lever to the "CLOSE" position.

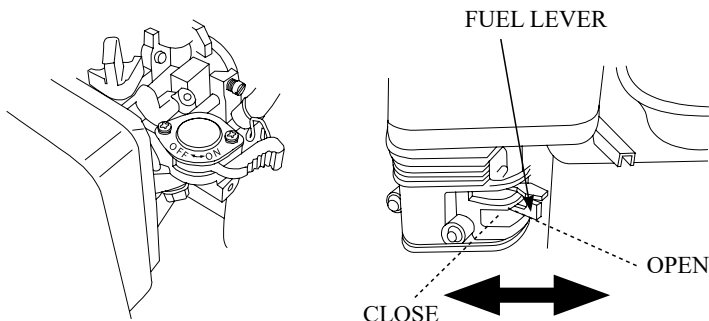

#### 2) Engine Switch

The engine switch is used for opening or closing ignition circuit :

Set the engine switch to the "OPEN" position to run the engine, and set it to the "CLOSE" position to stop the engine.

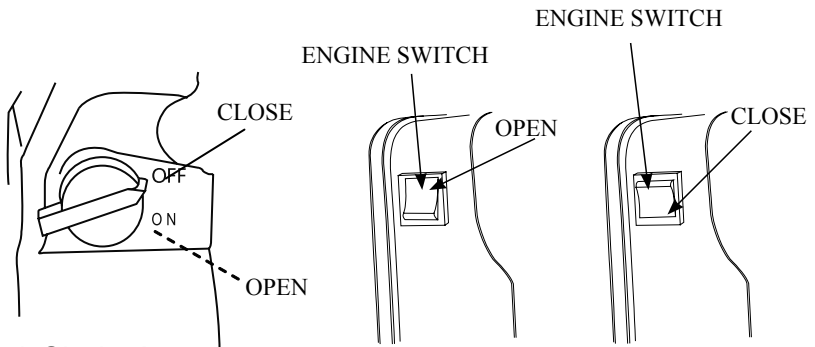

### 3) Choke Lever

The choke lever is used for opening and closing the choke of the carburetor.

Set the choke lever to the “CLOSE” position for cold starting.

Set the choke lever to the “OPEN” position for normal operation or the Engine's warm starting.

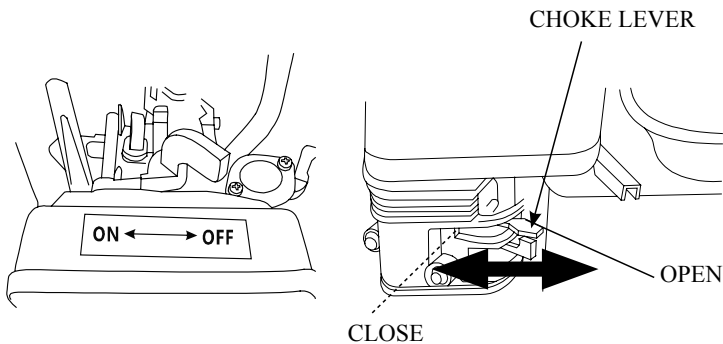

#### 4) Throttle Lever

Adjust the throttle lever to change speed of the engine, thereby adjust the discharge water. For a bigger water discharge, set the throttle lever to the HIGH position, for a smaller water discharge, set the throttle lever to the LOW position.

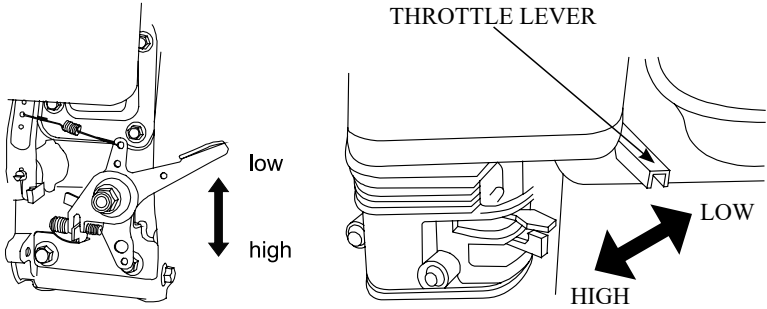

#### 5) Recoil Starter

Pull the recoil starter to start the engine.

**NOTICE**

**Don't allow the starter grip to snap back against the engine. Return it gently to prevent damage to the starter**

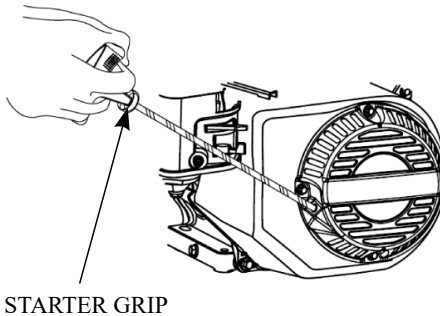

## 4. PRE-OPERATION INSPECTION

For your safety and to maximize the service life of your equipment, it is very important to take a few moments before you operate the pump to check its condition. Be sure to take care of any problem you find or have your servicing dealer correct it, before you operate the pump.



**Improperly maintaining this pump or failing to correct problems before operation could cause a malfunction in which you could be seriously injured.**

Exhaust gas contains poisonous carbon monoxide. Avoid inhalation of exhaust gas. Never run the engine in a closed garage or an enclosed area. To prevent fire hazards, keep the pump at least 1m away from each of the building walls and other equipment during operation. Do not place flammable objects close to the engine.

Before beginning your pre-operation checks, be sure the pump is on a level surface and the ignition switch is in the OFF position.

### 1) Routine Check

Look around and underneath the pump for signs of oil or gasoline leaks.

Remove any excessive dirt or debris, especially from around the engine muffler and recoil starter.

Look for signs of damage.

Check to confirm that all nuts, bolts, screws, hose connectors and clamps are tightened.

## 2) Check The Suction And Discharge Hoses

Check the general condition of the hoses. Be sure the hoses are in serviceable condition before connecting them to the pump. Remember that the suction hose must be of a reinforced construction to prevent hose collapse.

Check to ensure that the sealing washer in the suction hose connector is in a good condition.

Check to ensure that the hose connectors and clamps are securely installed.

Check to ensure that the strainer is in a good condition and is installed on the suction hose.

## 3) Check Engine Oil

### **NOTICE**

**Put the engine on a level place and check the engine oil.**

- 1) Remove the oil filler cap and wipe the dipstick clean.
- 2) Check the oil level by inserting the dipstick into the filler neck without screwing it in.
- 3) If the level is low, add the recommended oil to the upper mark on the dipstick.
- 4) After adding, don't forget to refit and screw down the oil dipstick.

OILING HOLE

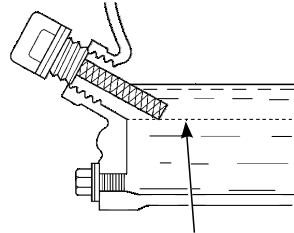
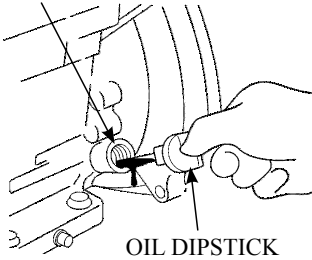

OIL LOWER MARK

**NOTICE**

Engine operating with oil at the lower oil mark will cause engine damage.

#### 4) Check Air Filter

A dirty air filter will restrict air flow to the carburetor, reduce engine performance and thereby reduce water Pump performance. So, often check the air filter.

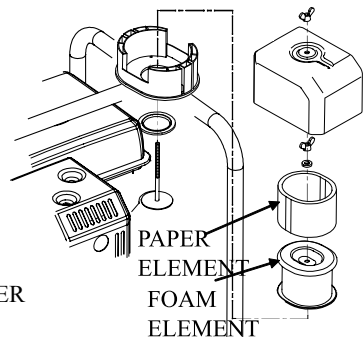
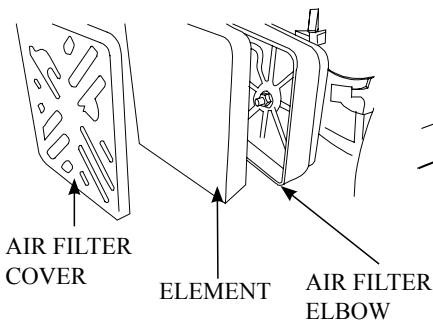

Screw off butterfly nut and remove air filter housing, If the element is

dirt, clean it, if it is damaged, replace with a new one. If it is an oil bath air filter, Check the oil capacity.

Reinstall the air filter back in reverse order and screw the butterfly nut down.

**NOTICE**

**Assembly should be correct, Never run the water pump without the air filter or with a damaged air filter assembled, if so, rapid engine wear will result.**

## 5) Check The Fuel

Before each operation, check the engine oil level with the water pump stopped on a level ground. Screw off the fuel tank cap and check the fuel level. If the level is too low, add fuel, screw on the fuel tank cap and tighten it after refueling.

**NOTICE**

**Don't add the fuel over the fuel strainer shoulder(maximum level).**

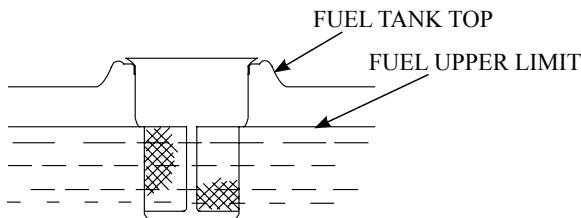



Refuel in a well-ventilated area. If the engine has run for a while, it has to be cooled before being refueled.

**NOTICE**

**Fuel can damage paint and plastic. Be careful not to spill fuel when filling your fuel tank.**

## 6) Fuel Recommendations

Use gasoline with octane rating  $\geq 90$ .

We recommend unleaded gasoline because it produces fewer engine deposit and spark plug deposit and extends exhaust system's life.

Never use stale or contaminated gasoline or oil/gasoline mixture. Avoid getting dirt or water in the fuel tank.

## **5. OPERATION**

### **1) Safe Operating Precautions**

To safely utilize the full potential of this pump, you need a complete understanding of its operation and a certain amount of practice with its controls.

Before operating the pump for the first time, please review the "Safety Instruction" (refer to page 4) and the "PRE-OPERATION INSPECTION".( refer to page 18)

Exhaust contains poisonous carbon monoxide gas that can build up to dangerous levels in closed areas. Breathing carbon monoxide can cause unconsciousness or death.

### **2) Pump Placement**

For best pump performance, place the pump near the water level, and use hoses that are no longer than necessary. That will enable the pump to produce the greatest output with the least self-priming time.

As head increases, pump output decreases, The length, type and size of the suction and discharge hoses can also significantly affect pump output. Minimizing suction head (placing the pump near the water level) is also very important for reducing self-priming time.

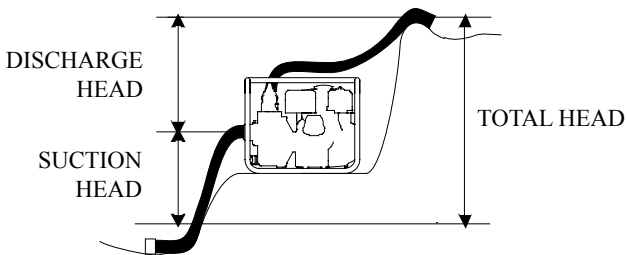

### 3) Suction Hose Installation

Use the commercially available hose and hose connector, and the hose clamp provided with the pump to install the suction, and tighten the clamp. Firmly fix the suction hose without moving.

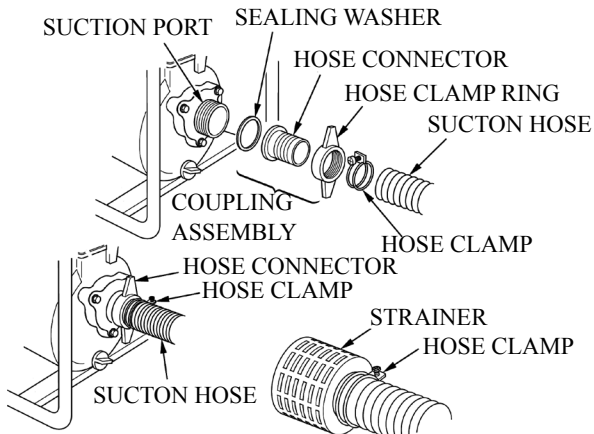

Hose dimension should be longer than water suction port dimension.  
Minimum hose dimension shall be as following:

SEV-25S: 1 " ( 25 mm ), SEV-50S: 2 " ( 50 mm ), SEV-80S: 3 " ( 80 mm )

Use a hose clamp to securely fasten the hose connector to the suction in order to prevent air and water leakage. Check to ensure that the hose connector sealing washer is in a good condition.

Install the strainer (provided with the pump) on the other end of the suction hose and secure it with a hose clamp. The strainer will help prevent the pump from becoming clogged or damaged by debris.

The strainer should be installed in the position where water accumulates most easily. When installing on weak ground, such as gravel or sand, position wooden boards or blocks, etc. below the strainer to prevent it from sinking into the ground.

#### 4) Discharge Hose Installation

Use the commercially available hose and hose connector, and the hose clamp provided with the pump to install the discharge, and tighten the clamp. Firmly fix the discharge hose without moving.

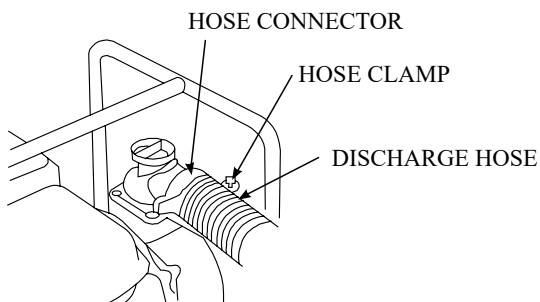

If the discharge hose must run across a roadway, the hose should cross the roadway perpendicular to traffic flow. Also, heavy boards should be placed next to the hose so the motor vehicle weight does not shut off the discharge as vehicles cross over the hose.

It is best to use a short, large-diameter hose, because that will reduce fluid friction and improve pump's output.

Tighten the hose clamp securely to prevent the discharge hose from disconnecting under a high pressure.

## 5) Priming The Pump

Before starting the engine, make sure to fill the pump with water: screw off the priming plug and prime the pump fully with clean water. Don't screw off the priming plug during operation of the pump to avoid damaging the equipment and injuring persons. Reinstall the priming plug and tighten it securely after priming.

### NOTICE

**Dry operating of the pump will destroy the pump seal. If the pump has been operated in a dry state, stop the engine immediately and allow the pump to cool before being primed.**

PRIMING WATER FILLER CAP

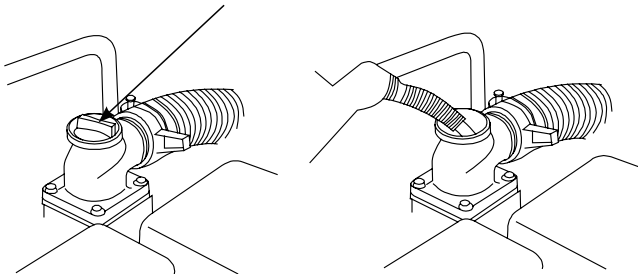

## 6. STARTING THE ENGINE

- 1) Screw the priming plug off and prime the pump with water until the water is overflowing (water pump set shall be placed on a level ground).
- 2) (SEV-50S, -80S only) Move the fuel valve lever to the “ON” position.

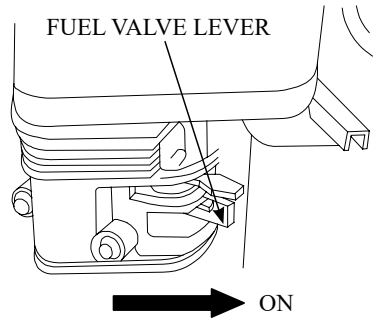
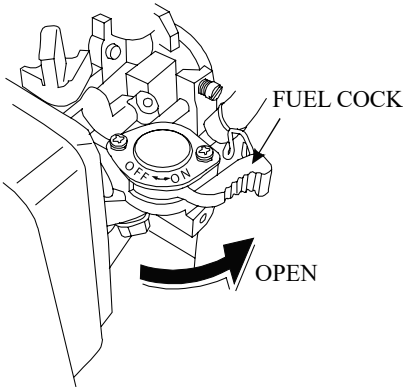

- 3) To start a cold engine, move the choke lever to the “CLOSED” position.

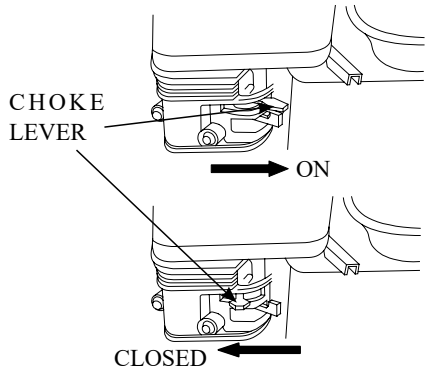
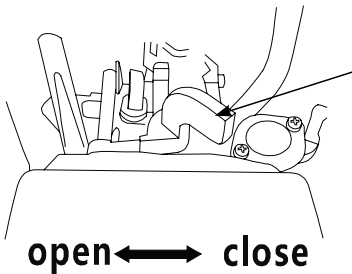

- 4) Move the throttle lever away from the “SLOW” position about 1/3 of the way toward the “FAST” position.

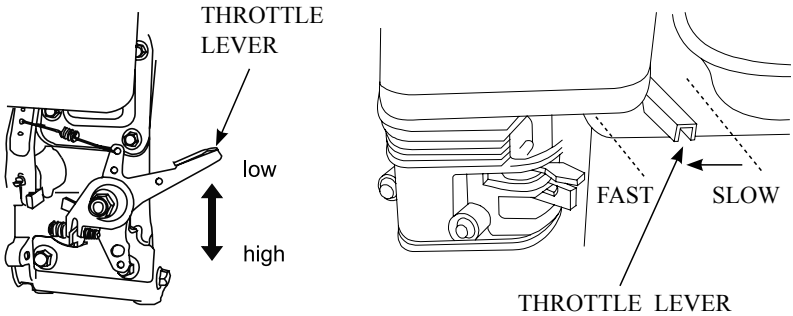

- 5) Turn the engine switch to the “ON” position.

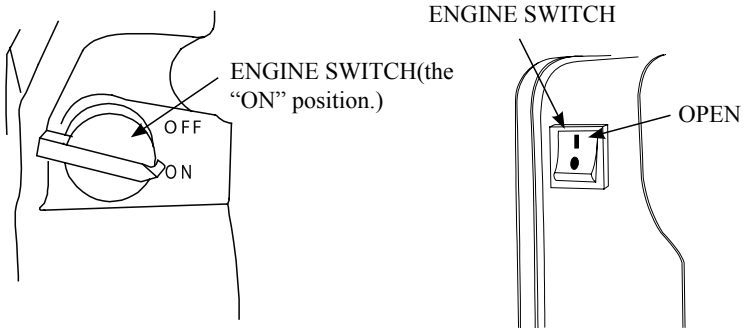

- 6) Pull the starter grip lightly until resistance is felt, then pull it briskly.

#### NOTICE

**Do not allow the starter grip to snap back against the engine. Return it gently to prevent damage to the starter.**

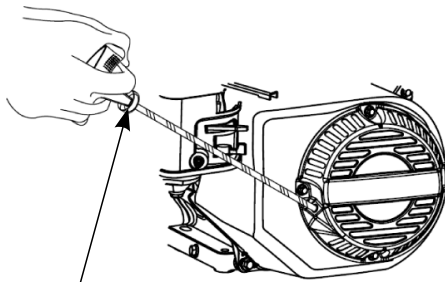

STARTER GRIP

7) If the choke lever was moved to the CLOSED position to start the engine, gradually move it to the OPEN position as the engine warms up.

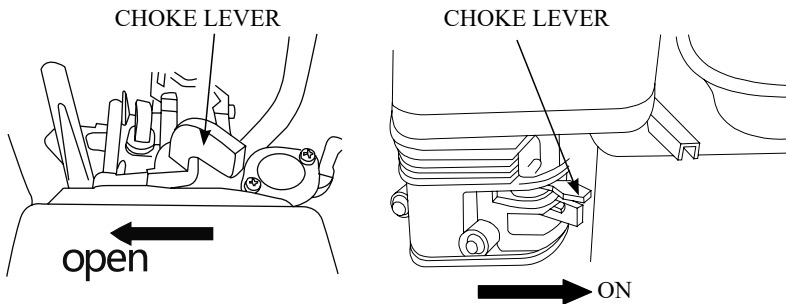

8) Setting engine speed

After starting the engine, move the throttle lever to the FAST position for self-priming, and check pump output.

Pump output is controlled by adjusting engine speed, moving the throttle lever in the FAST direction will increase pump output, and moving the throttle lever in the slow direction will decrease pump output.



## 7. STOPPING THE ENGINE

To stop the engine in an emergency, simply turn the engine switch to the OFF position.

Under normal conditions, use the following procedure:

- 1) Move the throttle lever to the SLOW position.

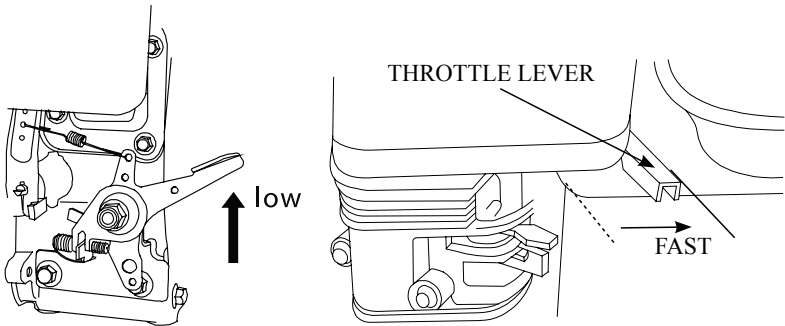

- 2) Turn off engine switch: Turn the engine switch to OFF position.

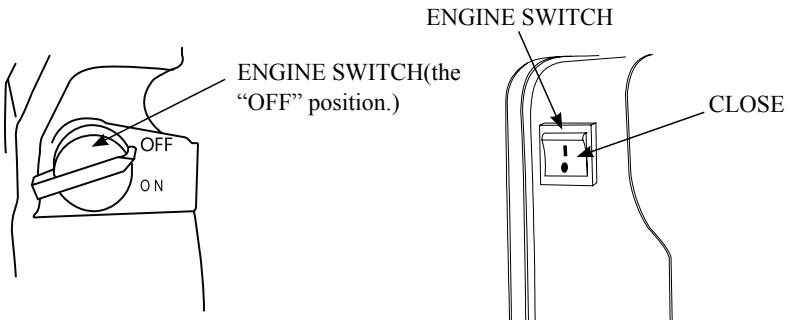

3) (SEV-50S, -80S only) Turn fuel valve lever off:  
Turn the fuel valve lever to OFF position.

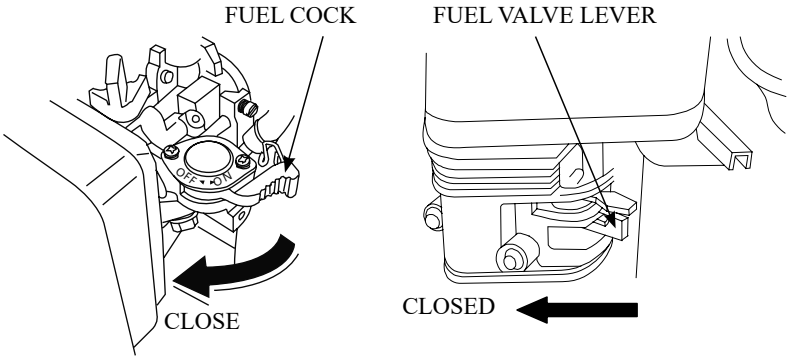

After use, remove the pump drain plug and drain the pump chamber. Remove the filler cap and flush the pump chamber with clean, fresh water. Allow the water to drain from the pump chamber, then reinstall the filler cap and drain plug.

## 8. MAINTENANCE

The engine must be properly maintained to ensure its operation be safe, economy and trouble-free, as well as eco-friendly.

In order to keep your gasoline engine in good working condition, it must be periodically serviced. The following maintenance schedule and routine inspection procedures must be carefully followed

Items		Frequency	Each time	First 1 month or first 20hrs of operation	Thereafter, every 3 months or every 50hrs of operation	Every year or every 100 hrs of operation
Engine oil	Check- Refill		√			
	Replace			√	√	
Reduction gear oil(if equipped)	Oil level check		√			
	Replace			√	√	
Air filter element	Check		√			
	Clean			√		
	Replace				√	
Deposit Cup( if equipped)	Clean					√
Spark Plug	Check - adjust					√*
Spark arrester	Clean				√	
Idling ( if equipped)**	Check - adjust					√
Valve clearance **	Check-adjust					√
Fuel tank & fuel filter **	Clean					√
Fuel line	Check	Every 2 years( change if necessary)				
Cylinder head, piston	Clean up carbon **	< 225cc, Every 125hrs ≥ 225cc, Every 250hrs				

\* These items should be replaced if replacement needed.  
\*\* These items should be maintained and repaired by our authorized dealer, unless the owner has appropriate tools and is proficient with mechanical maintenance.

### NOTICE

- If the gasoline engine frequently work under high temperature or heavy load, change the oil every 25 hours.
- If the engine frequently work under dusty or other severe circumstances, clean the air filter element every 10 hours; If necessary, change the air filter element every 25 hours.
- The maintenance period and the exact time (hour), the one which comes first

should govern.

- If you have missed the scheduled time to maintain your engine, do it as soon as possible.



**Stop the engine before servicing. Put the engine on a level surface and remove the spark plug cap to prevent the engine from starting. Never run your engine in a poorly ventilated room or other enclosed area, be sure to keep good ventilation in working area. The exhaust from the engine may contain poisonous CO, inhalation can cause shock, unconsciousness and even death.**

## 2) Engine oil change

Drain the used oil while the engine is warm. Warm oil drains quickly and completely.

1. Place a suitable container below the engine to catch the used oil, then remove the oil filler cap/dipstick and the drain plug.
2. Allow the used oil to drain completely, then reinstall the drain plug, and tighten it securely.

Please dispose of used motor oil in a manner that is unharful to with the environment. We suggest you take used oil in a sealed container to your local recycling center or service station for reclamation. Do not throw it in the trash, pour it in the ground, or down into a drain.

3. With the engine on a level place, fill it to the upper limit with the recommended oil.

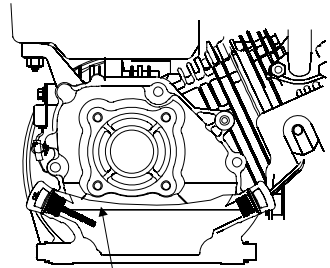
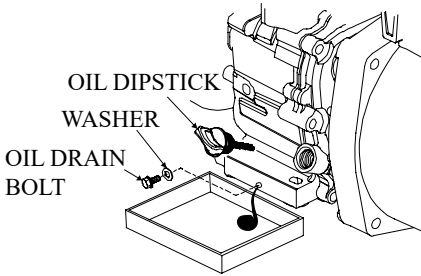

UPPER MARK

4. Reinstall the oil dipstick and tighten it.

**CAUTION**

Used engine oil may cause skin cancer if repeatedly left in contact with the skin for prolonged periods. Although this is unlikely unless you handle used oil on a daily basis, it is still advisable to thoroughly wash your hands with soap and water as soon as possible after handling used oil.

### 3) Engine oil recommendations

Engine oil is a major factor affecting engine performance and service life. Non-detergent and 2-stroke engine oils will damage the engine and are not recommended.

Recommended oil

4-stroke gasoline oil

SE, SF grades under API service

Classification or SAE10W-30 that is equivalent SG grade. Of course, you can select according to local temperature.

The recommended operating range of this pump: 5°C to 45°C.

#### SAE VISCOSITY GRADES

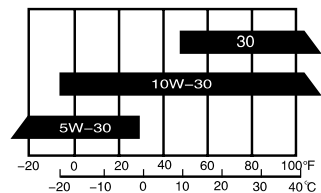

#### AMBIENT TEMPERATURE

#### 4) Air Filter Service

A dirty air filter element will restrict air flow to the carburetor, reducing engine performance, if you operate the pump in very dusty areas, clean the air filter more frequently than specified in the maintenance schedule.

##### **NOTICE**

**Never run the engine without the air filter or use a damaged air filter. If so, rapid engine wear will result.**

Remove the air filter and the element.

1. Wash the element with home detergents and warm water (or non-flammable or high flash-point cleansing solvents) and dry it up.
2. Soak it in clean engine oil until it is saturated. Squeeze out excess oil.
3. Clean the lower body of the air filter, housing, and rubber cushion. Prevent dusts from entering into the air path of the carburetor.
- 4 Reinstall all the parts of the air filter, including the element.

#### 5) Spark Plug Service

Recommended spark plugs: refer to 11. SPECIFICATION

##### **NOTICE**

**Wrong model can result in engine damage.**

1. Remove the spark plug cap, and clean any dirt from around the spark plug base.
2. Use the plug wrench to remove the spark plug.
3. Measure the plug gap with a feeler gauge. If the electrode or insulator

is damaged, replace the spark plug.

Correct as necessary by carefully bending the side electrode. The gap should be: 0.70-0.80 mm.

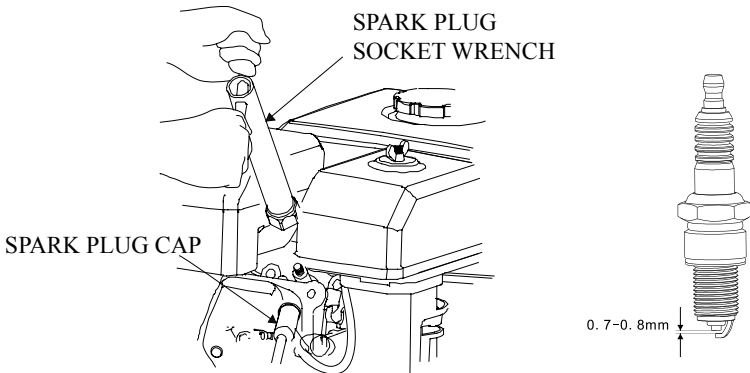

4. Check if the spark plug gasket is in good condition. In order to avoid damage to the thread in the cylinder head, screw in the spark plug carefully by hand.
5. Once the spark plug has touched the washer, screw it down by a spark plug wrench and compress the washer.
  - If a new spark plug is used, make 1/2 turn more after compressing the gasket.
  - If reinstalling the used spark plug, just make 1/8-1/4 turn more.
6. Install the spark plug cap.

## 9. STORAGE

- 1) Remove priming plug and drain plug, flush the chamber with clean water, reinstall the priming plug and drain plug. After stopping the engine, cool for half an hour at least, then flush all outer surfaces and wipe it.

### NOTICE

**Higher pressure flushing water can enter into the air filter and muffler, even entering into the cylinder along the air path, resulting in corrosion and damage. So, operation must be performed only after stopping and cooling.**

- 2) Remove drain plug of the carburetor and sediment cup, then open the fuel lever. Completely drain the fuel from the carburetor and fuel tank, then install the sediment cup and drain plug back and tighten them.

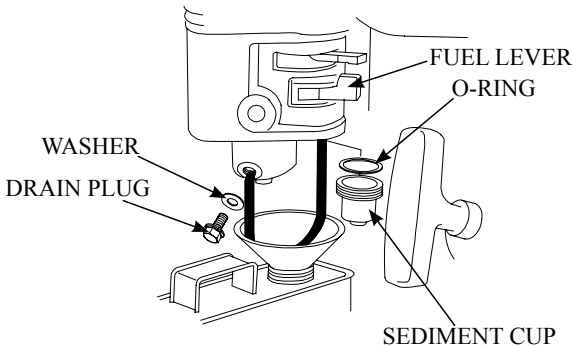

- 3) Change the engine oil.
- 4) Pour a tablespoon (5-10 cc) of clean engine oil into the cylinder. Crank the engine several revolutions to distribute oil in the cylinder. Reinstall the spark plug back.



- 5) Pull the starter grip slowly until resistance is felt. During such a process, intake and exhaust valves keep closed to restrict the moisture entering into cylinder head, then, return the starter grip gently.
- 6) Repair damaged enamel paint, and apply a thin film of grease to the areas likely to be rusty.
- 7) Cover a dust-proof sleeve on the water pump and place it in the ventilated area.

## 10. TROUBLESHOOTING

### 1) Engine

ENGINE WILL NOT START	CAUSE	CORRECTION
Check Control Parts	Fuel valve OFF.	Move fuel valve lever to ON position.
	Choke open.	Move choke lever to CLOSED position unless engine is warm.
	Engine switch OFF.	Turn engine switch to ON.
Check Fuel	Out of fuel.	Refuel.
	Bad fuel, pump stored without treating or draining gasoline or refueling with bad gasoline.	Drain fuel tank and carburetor, refuel with fresh gasoline.
Remove And Inspect Spark Plug	Spark plug faulty fouled or improperly gapped.	Adjust gap or replace with a new spark Plug
	Spark plug wet with fuel(flooded engine).	Dry and reinstall spark plug, start engine with throttle lever in FAST position.
Contact Our Company's Authorized Dealer For Servicing	Fuel filter clogged, carburetor malfunction, ignition malfunction, valves stuck, etc.	Replace or repair.

ENGINE LACKS POWER	CAUSE	CORRECTON
Check Air Filter Element	Element clogged.	Clean or replace the element.
Check Fuel	Bad fuel.	Drain fuel tank and carburetor, refuel with fresh gasoline.
Contact Our Company's Authorized Dealer For Servicing	Fuel filter clogged, carburetor malfunction, ignition malfunction, valves stuck, etc.	Replace or repair.

## 2) Water pump

NO PUMP OUTPUT	CAUSE	CORRECTION
Check pump chamber	Pump not primed.	Prime pump.
Check suction hose	Hose collapsed, cut or punctured.	Replace hose.
	Strainer not completely underwater.	Sink the strainer and the end of a suction hose completely underwater.
	Air leak at connector.	Replace sealing washer if it is missing or damaged. Tighten hose connector and clamp.
	Strainer clogged.	Clean debris from strainer.
Measure suction and discharge head	Excessive head.	Relocate pump and hoses to reduce head.
Check engine	Engine lacks power.	See “engine lacks power”

LOW PUMP OUTPUT	CAUSE	CORRECTION
Check Suction Hose	Hose collapsed, cut or damaged, too long, or diameter too small.	Replace hose.
	Strainer not completely underwater.	Sink the strainer and the end of a suction hose completely underwater.
	Air leak at connector.	Replace sealing washer if it is missing or damaged. Tighten hose connector and clamp.
Check Discharge Hose	Hose damaged, too long, or diameter too small.	Replace discharge hose.
Measure Suction And Discharge Head	Critical head.	Relocate pump and hoses to reduce head.
Check Engine	Engine lacks power.	See “engine lacks power”

## 11. SPECIFICATION

Product name		Clear water pump	
Model name		SEV-25S	
Category		Self-priming, Centrifugal pump	
Pump	Connection dia	Suction	1" (25 mm)
		Discharge	1" (25 mm)
	Connection thread		Outer pipe thread NPT
	Total head		95 ft (29 m)
	Discharge volume		36 USG/min (140 L/min)
	Max. suction head		19 ft (6 m)
Engine	Type		Forced air-cooled 4-stroke gasoline engine
	Model		KOSHIN K80-V
	Displacement		0.02 USG (79 cm <sup>3</sup> )
	Rated output		1.6 HP (1.2 kW) / 3600 rpm
	Max. output		1.9 HP (1.4 kW) / 3600 rpm
	Fuel		Automotive unleaded gasoline
	Fuel tank capacity		Tank size: 0.46 USG (1.77 L), Usage level: 0.42 USG (1.61 L)
	Engine oil capacity		0.09 USG (0.35 L)
	Starting method		Recoil starter
Spark plug		NGK BP5HS or other equivalents	
Applicable liquids	Consistency		Clear water
	Suspended solid percentage		-
	Max. solids size		-
	Temperature		41-113 °F (5-45 °C)
Standard accessories		1 Strainer, 2 Coupling sets, 3 Hose bands, 1 Engine Tool, 1 Suction hose (9.8 ft (3 m))	
Net weight		30.6 lbs (13.9 kg)	
Gross weight		40.1 lbs (18.2 kg)	
Product dimensions L × W × H		16" x 12" x 14" (397 x 305 x 358 mm)	
Packing dimensions L × W × H		18" x 16" x 17" (435 x 405 x 415 mm)	

\*For the purpose of improvement, specifications are subject to change without notice.

\*Self-priming performance may decrease due to atmospheric pressure or outside air temperature. If self-priming lift is not enough, add priming water to pump casing.

Product name			Clear water pump	
Model name			SEV-50S	SEV-80S
Category			Self-priming, Centrifugal pump	
Pump	Connection dia	Suction	2" (50 mm)	3" (80 mm)
		Discharge	2" (50 mm)	3" (80 mm)
	Connection thread		Outer pipe thread NPT	
	Total head		98 ft (30 m)	85 ft (26 m)
	Discharge volume		166 USG/min (630 L/min)	298 USG/min (1130 L/min)
	Max. suction head		19 ft (6 m)	19 ft (6 m)
	Engine	Type		Forced air-cooled 4-stroke gasoline engine
Model		KOSHIN K210-S		
Displacement		0.06 USG (209 cm <sup>3</sup> )		
Rated output		5.0 HP (3.7 kW) / 3600 rpm		
Max. output		5.8 HP (4.3 kW) / 3600 rpm		
Fuel		Automotive unleaded gasoline		
Fuel tank capacity		Tank size: 0.87 USG (3.3 L), Usage level: 0.68 USG (2.6 L)		
Engine oil capacity		0.13 USG (0.5 L)		
Starting method		Recoil starter		
Spark plug		NGK BP6ES or other equivalents		
Applicable liquids	Consistency		Clear water	
	Suspended solid percentage		-	
	Max. solids size		-	
	Temperature		41-113 °F (5-45 °C)	
Standard accessories			1 Strainer, 2 Coupling sets, 3 Hose bands, 1 Engine Tool	
Net weight			45.6 lbs (20.7 kg)	50.0 lbs (22.7 kg)
Gross weight			50.0 lbs (22.7 kg)	55.6 lbs (25.2 kg)
Product dimensions L x W x H			19" x 16" x 17" (478 x 395 x 412 mm)	20" x 16" x 18" (497 x 395 x 443 mm)
Packing dimensions L x W x H			21" x 17" x 17" (520 x 420 x 430 mm)	21" x 17" x 19" (520 x 420 x 470 mm)

\*For the purpose of improvement, specifications are subject to change without notice.

\*Self-priming performance may decrease due to atmospheric pressure or outside air temperature. If self-priming lift is not enough, add priming water to pump casing.

### Performance curve

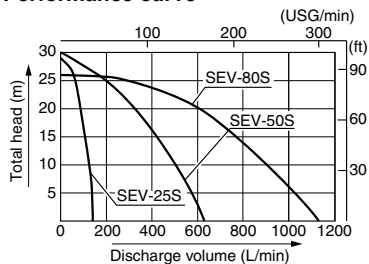

Note: Performance ratings are guaranteed minimum, not inflated maximum.

### Adjusting parameter

Spark plug gap	0.70-0.80 mm
Engine idle speed	1600 ± 160 rpm
Valve clearance (cooled)	Intake valve: 0.10-0.15 mm Exhaust valve: 0.15-0.20 mm



93004-V600110-00E0