

PGH-50

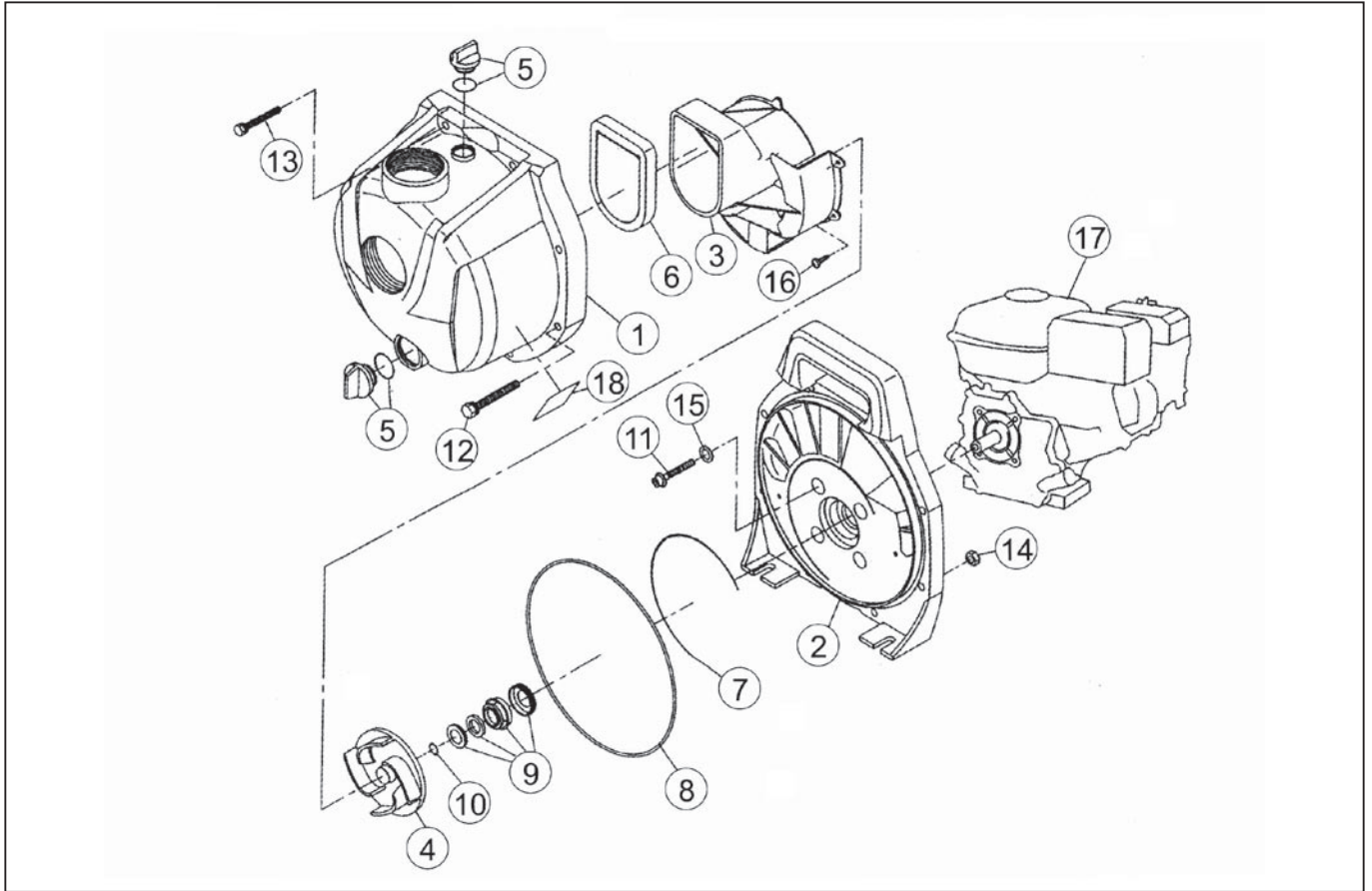

DWG No. 013850202 MODEL:PGH-50 FORM:PGH-50-BAA

No.	PARTS CODE	PARTS NAME	QTY	MATERIAL	SIZE	REMARKS
1	013000102	PUMP CASING	1	PET+GF15		
2	013000203	FLANGE BRACKET	1			
3	013000303	VOLUTE CASING	1	PET + GF		
4	013000402	IMPELLER	1	PET + GF		
5	013800101	20A PLUG SET	2			
6	013000901	CHECK VALVE	1	EPDM		
7	013000801	VOLUTE CASING PACKING	1	EPDM		
8	013000501	FLANGE PACKING	1	EPDM		
9	013001101	MECHANICAL SEAL	1			
10	011046601	ADJUSTING WASHER	2	BSP		
11	734705074	SOCKET BOLT M8X50	4	SUS	M8X50	
12	746205056	BOLT M8X55	6	SUS	M8X55	
13	746205057	BOLT M8X60	2	SUS	M8X60	
14	827405008	NUT M8	8	SUS	M8	
15	854255008	SEAL WASHER ϕ 8	4		ϕ 8	
16	718505035	+ TAPPING SCREW M4X12	3	SUS	4X12	
17	011544201	ENGINE	1	HONDA GC135WKT2		
18	013001801	NAME PLATE	1			

◆ Bare engine can not be supplied